



Lochinvar[®]
HIGH EFFICIENCY BOILERS & WATER HEATERS

**ARMOR X2
Condensing Water Heater
Submittal Sheet**

AWX-Sub-01c

ARMOR X2™ CONDENSING WATER HEATER

JOB NAME _____

LOCATION _____

ENGINEER _____

WHOLESALE _____

MECH. CONTRACTOR _____

MODEL NO. _____

TYPE GAS _____

Btu/hr INPUT _____

RECOVERY RATE IN GPH _____ @ _____ °F RISE

NOTES

STANDARD FEATURES

- › 96% Thermal Efficiency (AHRI Certified)
- › Modulating Burner with 10:1 Turndown
 - › Direct-Spark Ignition
 - › Low NOx Operation
 - › Sealed Combustion
 - › Low Gas Pressure Operation
 - › 2 Low Lead Circulating Pumps
- › Vertical & Horizontal Venting
 - › Category IV Venting up to 100 Feet
 - › PVC, CPVC, Polypropylene or AL29-4C Vent Material
 - › Sidewall Vent Termination Provided
- › ASME Stainless Steel Heat Exchanger
 - › Gasketless Design
 - › 160 psi Working Pressure
- › On/Off Switch
- › Adjustable High Limit with Manual Reset
- › Low Air Pressure Switch
- › Flow Switch
- › Inlet & Outlet Temperature Sensors
- › Two Easy Access Terminal Strips
- › Temperature & Pressure ASME Relief Valve
- › Zero Clearance to Combustible Material
- › Approved for Combustible Floor Installation
- › 1 Year Warranty on Parts
- › 5 Year Limited Warranty (see warranties for details)

SMART TOUCH™ FEATURES

- › SMART TOUCH™ Touchscreen Operating Control
 - › Full-Color Touchscreen LCD Display
 - › Built-in Cascading Sequencer for up to 8 Water Heaters
 - › Building Management System Integration with 0-10 VDC Input
 - › Password Security
 - › Low Water Flow Safety Control & Indication
 - › Inlet & Outlet Temperature Readout
 - › Freeze Protection
 - › Service Reminder
 - › Time Clock
- › Data Logging
 - › Hours Running
 - › Ignition Attempts
 - › Last 10 Lockouts
- › Programmable System Efficiency Optimizers
 - › Night Setback
 - › Anti-Cycling
- › Water Heater Pump Control
 - › High Voltage Terminal Strip
 - › 120 VAC / 60 Hertz / 1-Phase Power Supply
 - › Pump Contacts
- › Low Voltage Terminal Strip
 - › 24 VAC Auxiliary Device Relay
 - › Auxiliary Proving Switch Contacts
 - › Alarm on Any Failure Contacts
 - › Runtime Contacts
 - › Tank Thermostat Contacts
 - › Tank Sensor Contacts
 - › Cascade Contacts

OPTIONAL EQUIPMENT

- › Alarm Bell
- › Condensate Neutralization Kit
- › SMART TOUCH PC Software
- › Modbus Communications
- › Stainless Steel Vent Kits (1300 & 1500)
- › BMS Gateway to LON or BacNet

CODES & REGISTRATIONS

- › ANSI Z21.10.3 compliant
- › ASME certified, "HLW" stamp
- › California Code compliant
- › Massachusetts Code compliant
- › South Coast Air Quality Management District registered

Dimensions & Specifications

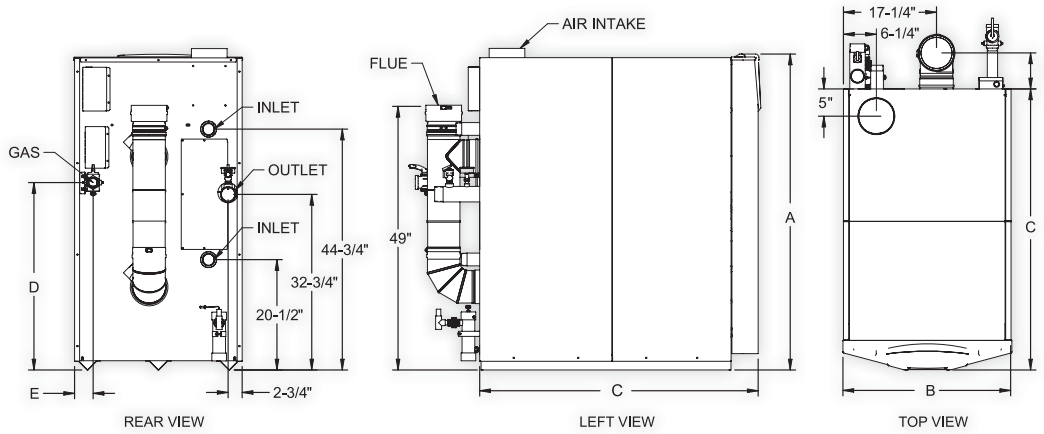

ARMOR X2 WATER HEATER				DIMENSIONS AND SPECIFICATIONS											
Model Number	Btu/hr Input	Thermal Efficiency	GPH @ 100° Rise	A	B	C	D	E	F	Gas Conn.	Inlet Water Conn.	Outlet Water Conn.	Air Inlet	Vent Size	Shipping Wt. (lbs.)
AWN1000PM	999,999	96.0%	1,164	58-3/4"	31"	48"	35"	4-1/2"	15"	1-1/2"	2 x 2"	3"	6"	6"	910
AWN1300PM	1,300,000	96.0%	1,513	58-3/4"	31"	52-1/4"	34-3/4"	3-1/2"	6-3/4"	1-1/2"	2 x 2"	3"	6"	6"	1049
AWN1500PM	1,500,000	96.0%	1,745	58-3/4"	31"	56-1/2"	34-3/4"	3-1/2"	6-3/4"	1-1/2"	2 x 2"	3"	6"	6"	1185

Notes: Change 'N' to 'L' for L.P. Gas Model. No deration on L.P. models. Performance data based on manufacturer test results. 120 VAC / 15 AMP circuit required. All dimensions shown in inches.



Lochinvar, LLC
 300 Maddox Simpson Parkway
 Lebanon, Tennessee 37090
 P: 615.889.8900 / F: 615.547.1000
 www.Lochinvar.com



LOW LEAD CONTENT HLW