



Ultra Low NOx Charger Commercial Gas Water Heaters

Dependable, Tank Type Water Heaters for Commercial and Industrial Applications

Ultra Low NOx Charger

The Ultra Low NOx Charger gas fired, tank type water heaters are designed to provide ease of installation, low stand-by loss and years of trouble free service. Chargers are ideally suited for apartments, schools, food service and many other commercial and industrial applications with up to 180°F service requirements. They are built to ensure easy installation and maintenance.

Ultra Low NOx Operation

Using unique fan assisted combustion, a blower is built into the ultra low NOx burner to deliver precise combustion that complies with SCAQMD rule 1146.2 for less than 14 ng/j or 20 ppm. Even with the advanced combustion design, the Charger is a Category I appliance using standard double wall "B" vent.

Outstanding Features / Quality Design

The Ultra Low NOx Charger features a multi-flue design for increased efficiency and fast heat transfer. The tank is glass lined for prolonged life and protection from rust and corrosion. The tank is certified for 150 psi working pressure and is available in standard construction or ASME construction over 200,000 Btu/hr input. Multiple anode rods are installed for additional protection from corrosion.

Ease of Installation

Ultra Low NOx Charger installations are fast and easy. The water heaters are fully assembled and ready for installation. The Charger has a small footprint and is often shorter than competing models. The Charger is designed with three sets of water circulation tappings. Water connections on the top, the front and the back provide ultimate flexibility, especially in retrofit applications.

Even More to Offer

All Ultra Low NOx Chargers feature spark ignition which is much more efficient than traditional standing pilots. Hand hole cleanouts and slide out burner trays offer superior serviceability. And all models are combustible floor approved.



Meets ASHRAE Energy Efficiency Standards

Dimensions and Specifications:

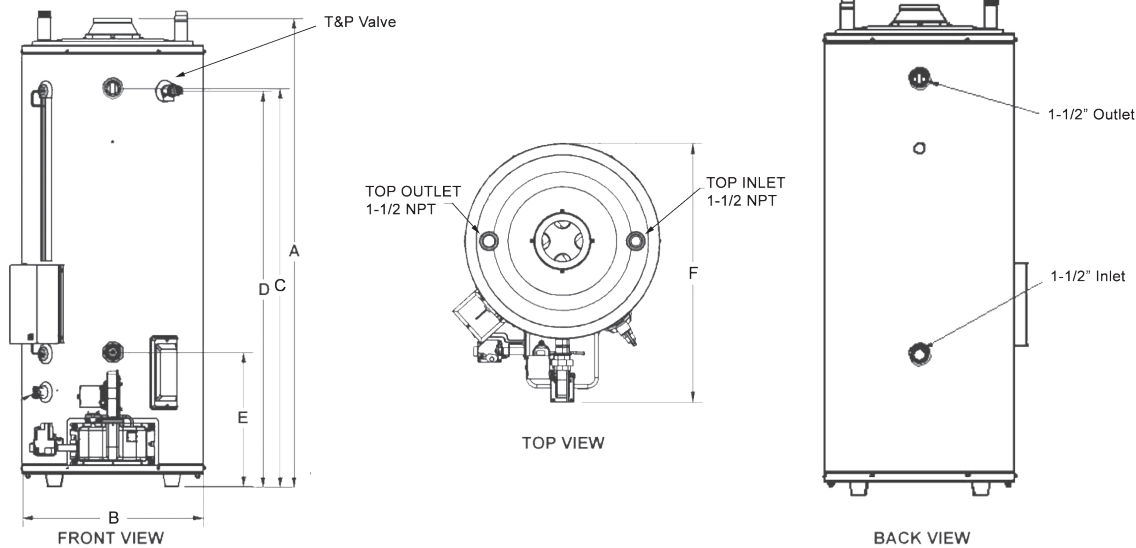

Model Number	Btu/hr Input	Capacity Gallons	GPH @ 100°F Rise	A	B	C	D	E	F	Vent Size	Gas Conn	Water Conn	Shipping Weight	Shipping Weight (ASME)
CLN120 080	120,000	81	115	63-3/4"	27-3/4"	53"	52-3/4"	20-3/4"	37"	6"	3/4"	1-1/2"	605	-
CLN154 080	154,000	81	148	63-3/4"	27-3/4"	53"	52-3/4"	20-3/4"	37"	6"	3/4"	1-1/2"	605	-
CLN180 080	180,000	81	173	63-3/4"	27-3/4"	53"	52-3/4"	20-3/4"	37"	6"	3/4"	1-1/2"	605	-
CLN199 100	199,000	100	191	71-3/4"	27-3/4"	61"	60-3/4"	20-1/2"	37"	6"	3/4"	1-1/2"	665	-
CLN250 100(A)	250,000	100	240	71-3/4"	27-3/4"	61"	60-3/4"	20-1/2"	37"	6"	3/4"	1-1/2"	665	715
CLN275 100(A)	275,000	100	264	71-3/4"	27-3/4"	61"	60-3/4"	20-1/2"	37"	6"	3/4"	1-1/2"	665	715
CLN310 085(A)	310,000	86	298	71-3/4"	27-3/4"	61"	60-3/4"	20-1/2"	37"	6"	3/4"	1-1/2"	740	790
CLN366 085(A)	366,000	86	352	71-3/4"	27-3/4"	61"	60-3/4"	20-1/2"	37"	6"	3/4"	1-1/2"	740	790
CLN400 085(A)	390,000	86	375	71-3/4"	27-3/4"	61"	60-3/4"	20-1/2"	37"	6"	3/4"	1-1/2"	740	790

A = ASME Construction

See the installation manual for dimensional information on Top and Back Tappings

Standard Features:

- 80% Thermal Efficiency
- Meets SCAQMD Rule 1146.2
- Multi-Flue Design
- Glass Lined Tank
- 150 PSI Working Pressure
- Tank Saver Anode
- ASME Temperature & Pressure Relief Valve
- Automatic Reset High Limit
- Spark Ignition
- 180°F Operation Approved
- Combustible Floor Approved
- Steel Jacket with Foam Insulation
- Hand Hole Cleanout
- Slide Out Burner Tray
- Rated Up to 10,000 Ft Altitude
- 3 Year Limited Warranty on Tank
- 1 Year Limited Warranty on Parts

Optional Equipment:

- UL Sanitation

FOR EASE IN ORDERING BY MODEL NUMBER

CL	N	120	080
Charger Low NOx	Natural Gas	Btu/hr Input	Gallon Capacity

This is a natural gas Charger Ultra Low NOx water heater. It has standard construction, 120,000 Btu/hr, and 80 gallon storage capacity.



Lochinvar, LLC
300 Maddox Simpson Parkway
Lebanon, Tennessee 37090
P: 615.889.8900 / F: 615.547.1000
Lochinvar.com

