

# INSTALLATION & SERVICE MANUAL

## ASME COMMERCIAL ELECTRIC WATER HEATER

**THE WARRANTY ON THIS WATER HEATER IS IN EFFECT ONLY WHEN THE WATER HEATER IS INSTALLED AND OPERATED IN ACCORDANCE WITH LOCAL CODES AND THESE INSTRUCTIONS. THE MANUFACTURER OF THIS WATER HEATER WILL NOT BE LIABLE FOR ANY DAMAGE RESULTING FROM FAILURE TO COMPLY WITH THESE INSTRUCTIONS. READ THESE INSTRUCTIONS THOROUGHLY BEFORE STARTING.**

*For safety, convenience, and best performance, we recommend this water heater be installed and serviced by a plumbing professional.*

**CONGRATULATIONS!**

You have just purchased one of the finest water heaters on the market today!

This installation, operation and instruction manual will explain in detail the installation and maintenance of your new ASME Commercial Electric Water Heater. We strongly recommend that you contact a plumbing professional for the installation of this water heater.

We require that you carefully read this manual, as well as the enclosed warranty, and refer to it when questions arise. If you have any specific questions concerning your warranty, please consult the plumbing professional from whom your water heater was purchased. For your records we recommend that you write the model, serial number and installation date of your water heater in the notes section in the back of this manual.

This manual should be kept with water heater.

### TABLE OF CONTENTS

<b>GENERAL INFORMATION .....</b>	<b>1</b>
<b>INSTALLATION .....</b>	<b>1</b>
<b>Locating The Water Heater .....</b>	<b>1</b>
<b>Water Connections .....</b>	<b>2</b>
<b>Electrical Connections .....</b>	<b>7</b>
<b>Amperage Chart .....</b>	<b>7</b>
<b>GPH Recovery Capacities .....</b>	<b>8</b>
<b>GENERAL OPERATION .....</b>	<b>8</b>
<b>Thermostat Adjustment .....</b>	<b>8</b>
<b>MAINTENANCE .....</b>	<b>9</b>
<b>SERVICING GUIDE .....</b>	<b>10</b>
<b>Notes .....</b>	<b>12</b>

### GENERAL INFORMATION

This electric water heater's design is certified by Underwriters Laboratories (UL) and listed in accordance with UL 1453. C-UL listed in accordance with Canadian National Standard Code C22.2, No. 110-M90.

This water heater must be installed in accordance with local codes. In the absence of local codes, install this water heater in accordance with the latest edition of the National Electrical Code.

The warranty for this water heater is in effect only when the water heater is installed, adjusted, and operated in accordance with these Installation and Operating Instructions. The manufacturer will not be held liable for damage resulting from alteration and/or failure to comply with these instructions.

This water heater has been designed and certified for the purpose of heating potable water. The installation and use of this water heater for any purpose other than the heating of potable water, may cause damage to the water heater and create a hazardous condition and nullify the warranty.

**▲ CAUTION**

**Incorrect operation of this appliance may create a hazard to life and property and will nullify the warranty.**

**DO NOT** use this appliance if any part has been submerged in water. The plumbing professional responsible for the installation of this water heater should be contacted to inspect the appliance and to replace any part of the control system, including thermostat(s), which has been submerged in water.

Make sure that the rating plate on the water heater is referenced so that the correct voltage is being supplied to the water heater.

**▲ DANGER**

**Do not store or use gasoline or other flammable, combustible, or corrosive vapors and liquids in the vicinity of this water heater or any other appliance.**

A sacrificial anode(s) is used to extend tank life. Removal of any anode, for any reason, will nullify the warranty. In areas where water is unusually active, or odor may occur at the hot water faucet due to a reaction between the sacrificial anode and impurities in the water. If this should happen, an alternative anode(s) may be purchased from the supplier that installed this water heater. This will minimize the odor while protecting the tank. Additionally, the water heater should be flushed with appropriate dissolvers to eliminate any bacteria.

**IMPORTANT**

Before proceeding, please inspect the water heater and its components for possible damage. **DO NOT** install any damaged components. If damage is evident, please contact the supplier where the water heater was purchased or the manufacturer listed on the rating plate for replacement parts.

### INSTALLATION

#### Locating The Water Heater

**▲ WARNING**

Water heaters are heat producing appliances. To avoid damage or injury, there shall be no materials stored against the water heater and proper care shall be taken to avoid unnecessary contact (especially by children) with the water heater. **UNDER NO CIRCUMSTANCES SHALL FLAMMABLE MATERIALS, SUCH AS GASOLINE OR PAINT THINNER BE USED OR STORED IN THE VICINITY OF THE WATER HEATER OR ANY LOCATION FROM WHICH FUMES COULD REACH THE WATER HEATER.**

This water heater **MUST NOT** be installed in any location where gasoline or flammable vapors are likely to be present, unless the installation is such to eliminate the probable ignition of gasoline or flammable vapors.

## Compact ASME

The location where this water heater is to be installed is of utmost importance. Before installing this water heater, consult the installation section of these instructions. After reading these installation and operating instructions, select a location for the water heater where the floor is level and is easily accessible to a power supply and water connections. It is recommended that the water heater be located near the center of greatest hot water usage to prevent heat loss through the pipes. **DO NOT locate the water heater where water lines could be subjected to freezing temperatures. Locate the water heater so that access panels, drain valves, and clean-out openings are accessible.**

Water heater corrosion and component failure can be caused by the heating and breakdown of airborne chemical vapors. Examples of some typical compounds that are potentially corrosive are: spray can propellants, cleansing solvents, refrigerator and air conditioning refrigerants, swimming pool chemicals, calcium or sodium chloride, waxes and process chemicals. These materials are corrosive at very low concentration levels with little or no odor to reveal their presence. **NOTE: DAMAGE TO THE WATER HEATER CAUSED BY EXPOSURE TO CORROSIVE VAPORS IS NOT COVERED BY THE WARRANTY. DO NOT OPERATE THE WATER HEATER IF EXPOSURE HAS OR WILL OCCUR. DO NOT STORE ANY POTENTIALLY CORROSIVE COMPOUNDS IN THE VICINITY OF THE WATER HEATER.**

This water heater must be located in an area where leakage from the tank, water line connections, and the combination temperature and pressure relief valve will not result in damage to the area adjacent to the water heater or to lower floors of the structure. When such locations cannot be avoided, a suitable drain pan must be installed under the water heater. The drain pan must be no greater than 1 ½ in. (3.8 cm) deep and have a minimum length and width of at least 4 in. (10.2 cm) measured from the jacket of the water heater. The drain pan, as described above, can be purchased from your plumbing professional. The drain pan must be piped to an adequate drain. The piping must be pitched for proper drainage.

### Water Connections

**Note: Before proceeding with the installation, close the main water supply valve.**

After shutting the main water supply valve, open a faucet to relieve the water line pressure in order to prevent water from leaking out of the pipes while making the water connections to the water heater. After the pressure has been relieved, close the faucet. The cold water inlet line connects to the inlet nipple at the base of the water heater. The hot water outlet line connects to the nipple on top of the water heater. The fittings at the cold water inlet and hot water outlet are dielectric waterway fittings with tapered male threads. Make the proper plumbing connections between the water heater and the plumbing system in the structure. Install a manual shut-off valve in the cold water supply line.

### ▲ CAUTION

If sweat fittings are to be used, **DO NOT** apply heat to the nipples on top of the water heater. Sweat the tubing to the adapter before fitting the adapter to the water heater connections. It is imperative that heat is not applied to the nipples containing a plastic liner.

### IMPORTANT

**FAILURE TO INSTALL AND MAINTAIN A NEW, LISTED TEMPERATURE AND PRESSURE RELIEF VALVE WILL RELEASE THE MANUFACTURER FROM ANY CLAIM WHICH MIGHT RESULT FROM EXCESSIVE TEMPERATURE AND PRESSURES.**

This water heater may be provided with an optional pressure and temperature gauge. See Figure 1 for proper installation.

If this water heater is installed in a closed water supply system, such as one having a back-flow preventer in the cold water supply, provisions must be made to control thermal expansion. **DO NOT** operate this water heater in a closed system without provision for controlling thermal expansion. Contact your water supplier or local plumbing inspector regarding how thermal expansion can be controlled.

After installation of the water lines, open the main water supply valve and fill the water heater. While the water heater is filling, open several hot water faucets to allow air to escape from the water system. When a steady stream of water flows through those faucets, close them and inspect all water connections for possible leaks. **NEVER OPERATE THE WATER HEATER WITHOUT FIRST BEING CERTAIN IT IS COMPLETELY FILLED WITH WATER.**

### ▲ WARNING

For protection against excessive temperatures and pressure, install temperature and pressure protective equipment required by local codes, but not less than a combination temperature and pressure relief valve certified by a nationally recognized testing laboratory that maintains periodic inspection of production of listed equipment or materials, as meeting the Requirements for *Relief Valves and Automatic Gas Shut-off Devices for Hot Water Supply Systems*, ANSI Z21.22, and the Standard *CAN1-4.4 Temperature, Pressure, Temperature and Pressure Relief Valves and Vacuum Relief Valves*. The combination temperature and pressure relief valve shall be marked with a maximum set pressure, not to exceed the maximum working pressure of the water heater. The combination temperature and pressure relief valve shall also have an hourly rated temperature steam Btu/hr discharge capacity not less than the hourly input rating of the water heater. Install the combination temperature and pressure relief valve into the opening on the water heater, which is provided for this purpose.

**Note:** Some models may already be equipped or supplied with a combination temperature and pressure relief valve. Verify that this combination temperature and pressure relief valve complies with local codes. If the combination temperature and pressure relief valve does not comply with local codes, replace it with one that does. Follow the installation instructions provided on this page.

Install a discharge line so that water discharged from the combination temperature and pressure relief valve will exit within six (6) inches (15.3 cm) above, or any distance below the structural floor and at a location where discharges cannot contact any live electrical part. This discharge line is to be installed for complete drainage of both the temperature and pressure relief valve and the discharge line can occur. The discharge opening must not be subjected to blockage or freezing. **DO NOT** thread, plug or cap the discharge line. It is recommended that a minimum of four (4) in. (10.2 cm) be provided on the side of the water heater for servicing and maintenance of the combination temperature and pressure relief valve. Do not place a valve between the combination temperature and pressure relief valve and the tank.

**▲ WARNING**  
 Hydrogen gas can be produced in the hot water system served by this water heater when there has been no usage for a long period of time (generally two weeks or more). Hydrogen gas is extremely flammable. Therefore, to reduce the risk of injury under these conditions, it is recommended that the hot water faucet be opened for several minutes at the kitchen sink before using any electrical appliance connected to the hot water system. If hydrogen is present, there will probably be an unusual sound, such as air escaping through the pipe, as the water begins to flow. There should be no smoking or open flame near the faucet at the time it is open.

**▲ CAUTION**  
**INCREASING THE THERMOSTAT SETTING ABOVE THE PRESET TEMPERATURE MAY CAUSE SEVERE BURNS AND CONSUME EXCESSIVE ENERGY. HOTTER WATER INCREASES THE RISK OF SCALD INJURY.**

This water heater can deliver scalding temperature water at any faucet in the system. Be careful whenever using hot water to avoid scalding injury. Certain appliances, such as dishwashers and automatic clothes washers, may require increased temperature water. By setting the thermostat on this water heater to obtain the increased temperature water required by these appliances, the potential for scald injury is increased. To protect against injury, install an anti-scald tempering valve in the water system. This valve will reduce the point of discharge water temperature by mixing cold and hot water in branch supply lines. Anti-scald tempering valves can be obtained from your local plumbing supplier. Please consult a plumbing professional.

**▲ DANGER**

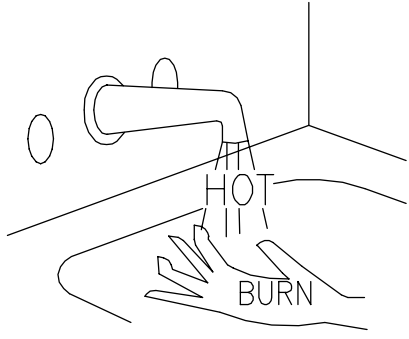

Water temperature over 125°F can cause severe burns instantly or death from scalds.

Children, disabled and elderly are at highest risk of being scalded.

See instruction manual before setting temperature at water heater.

Feel water before bathing or showering.

Temperature limiting valves are available, see manual.

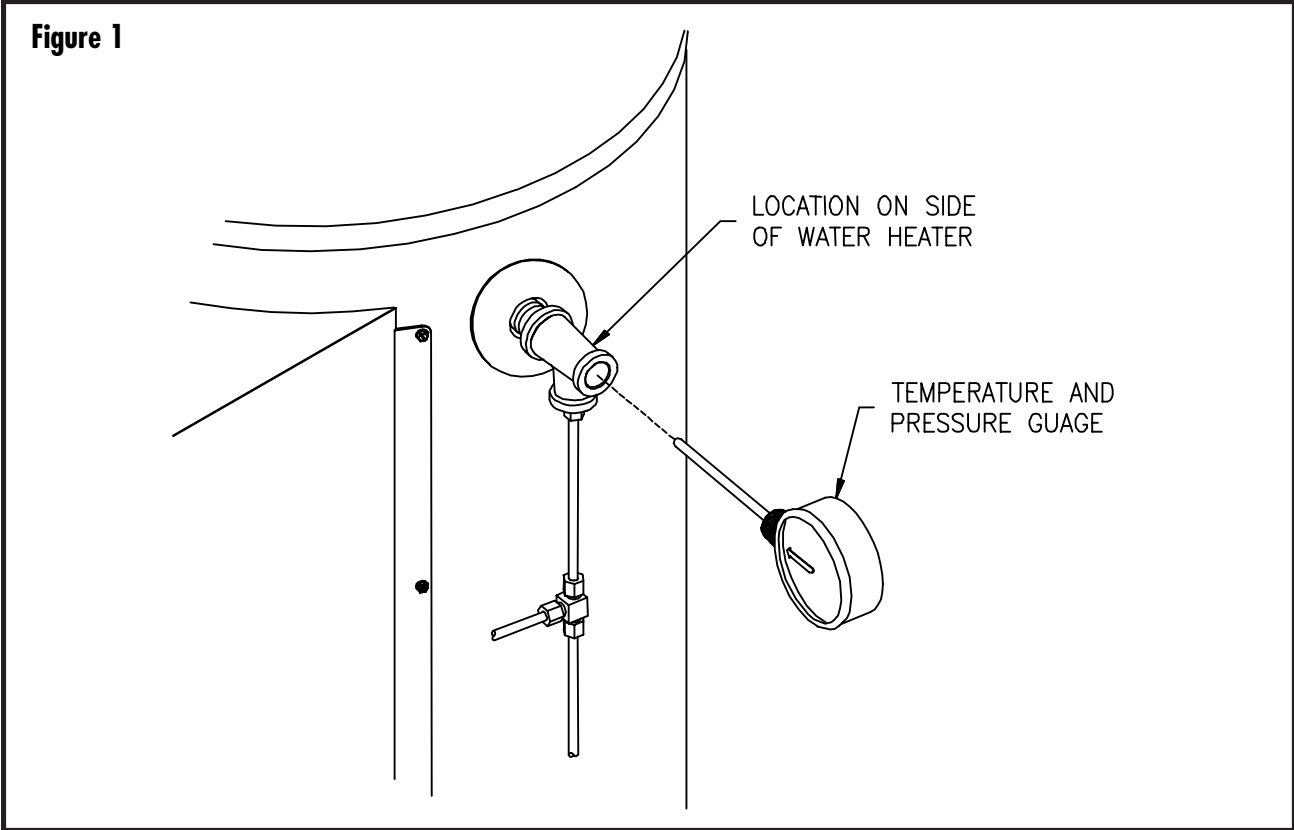
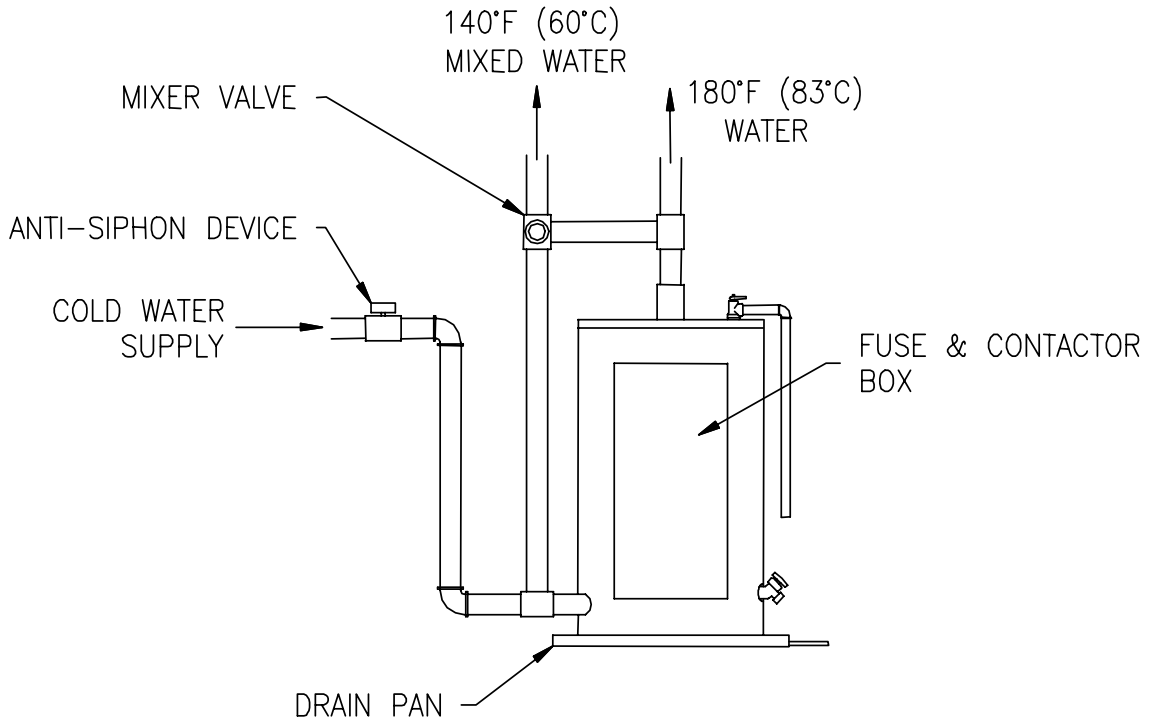
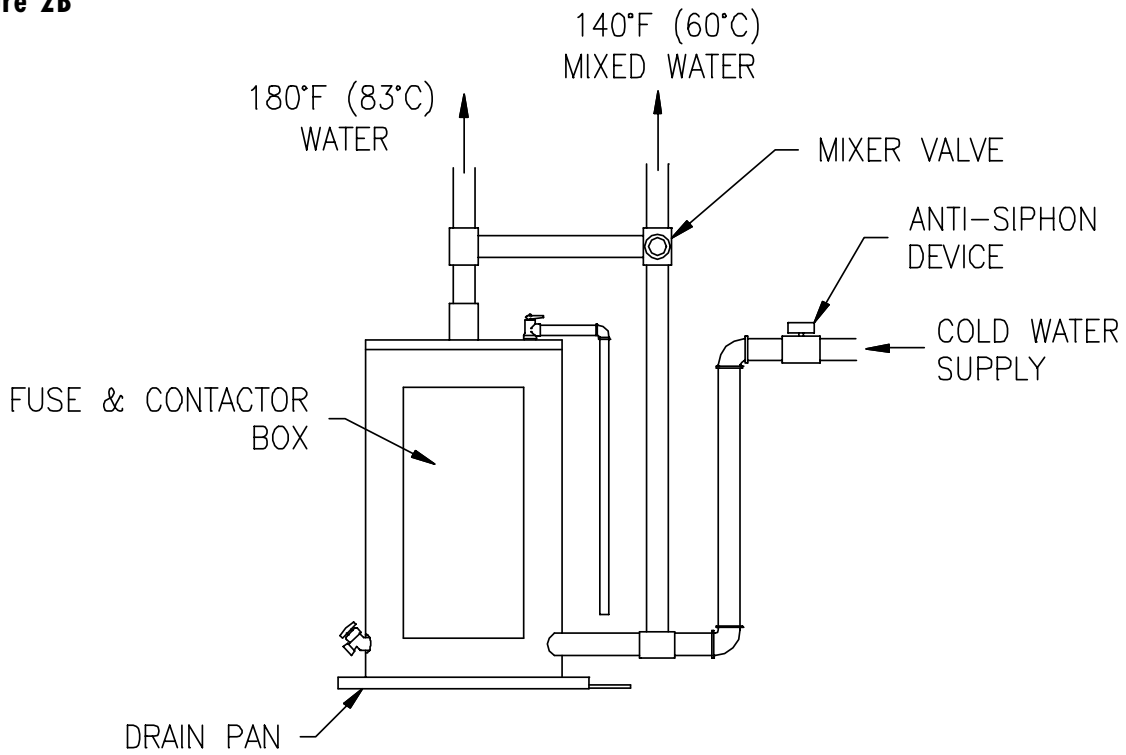

Figure 2A



**(Dual Temperature System with Mixing Valve)**  
**50A, 80A 120A**

Figure 2B



**(Dual Temperature System with Mixing Valve)**  
**6A, 12A, 20A, 30A 40A**

**Figure 3A**

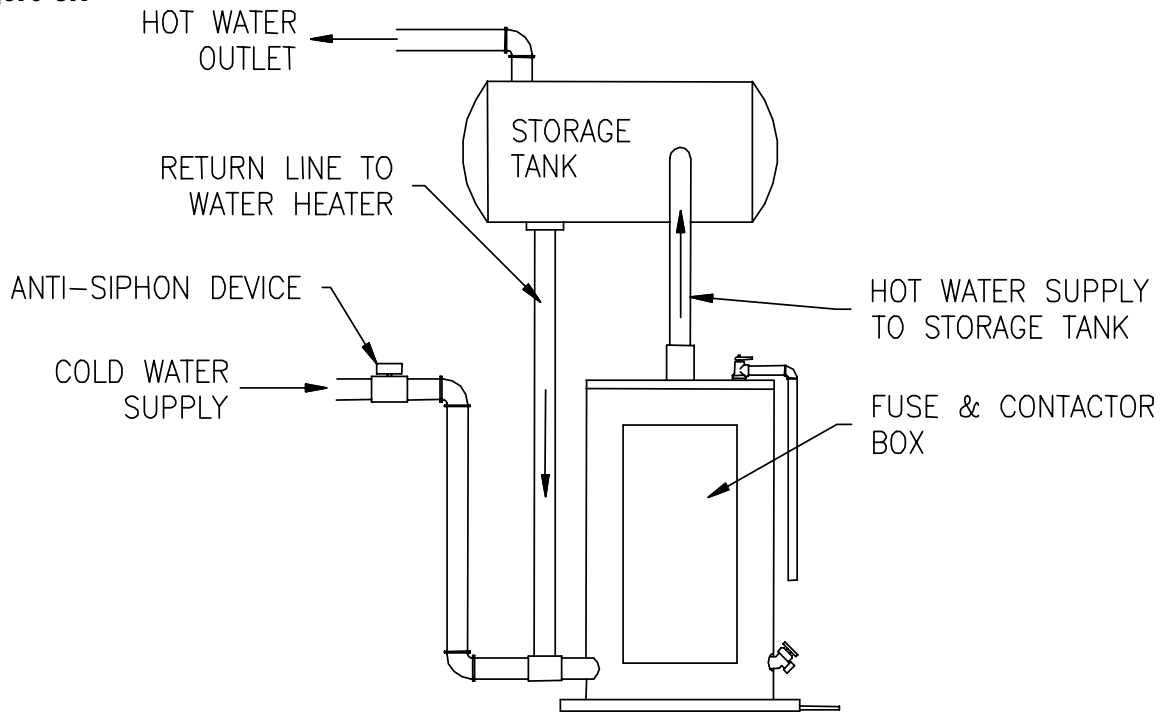

**(Single Installation with Storage Tank Gravity Circulation)**  
**50A, 80A, 120A**

**Figure 3B**

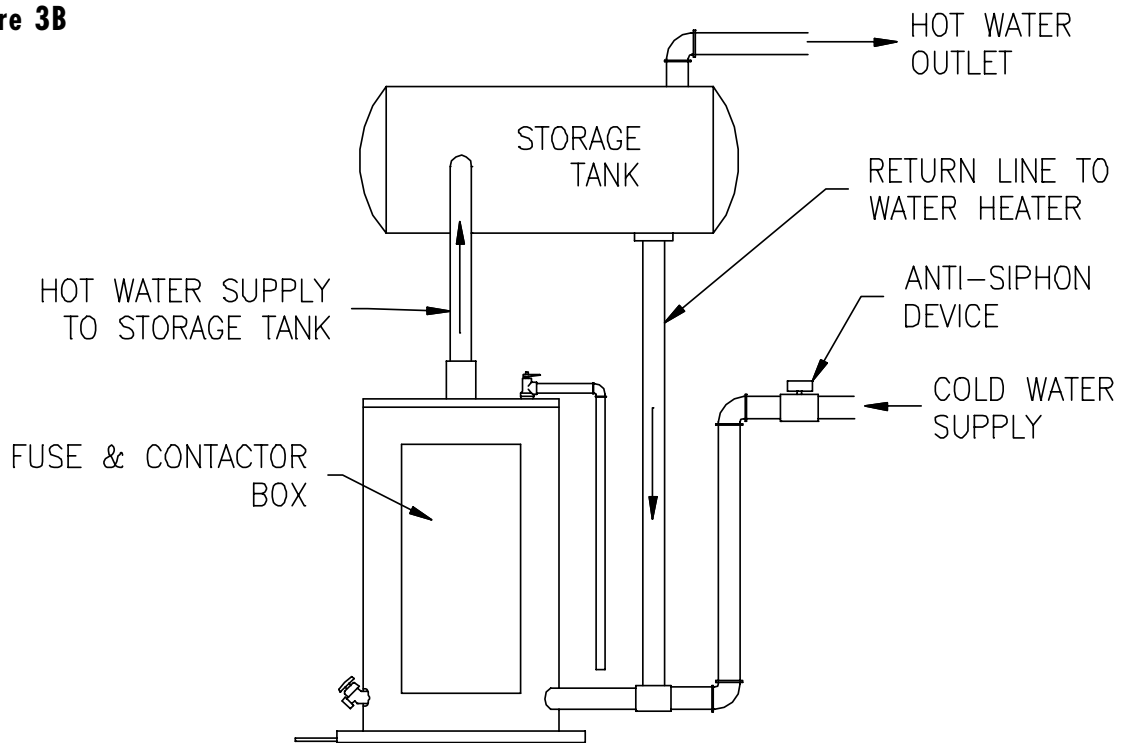

**(Single Installation with Storage Tank Gravity Circulation)**  
**6A, 12A, 20A, 30A, 40A**

**Figure 4A**

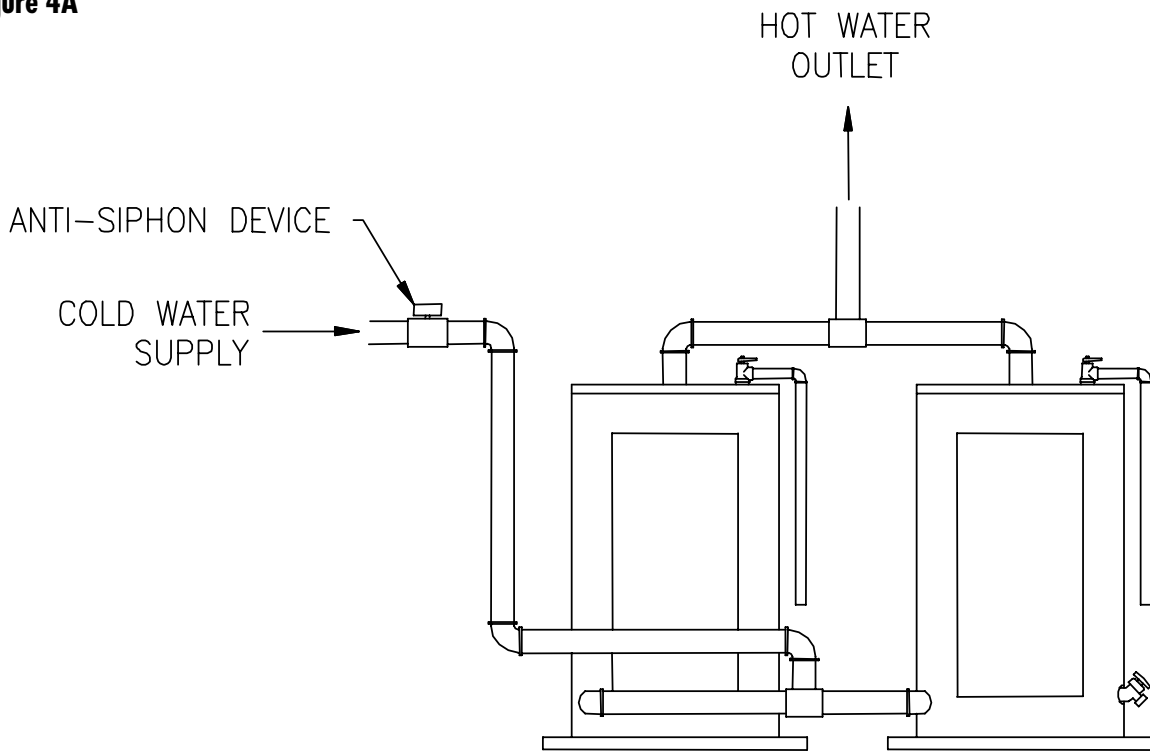

**(Dual Water Heater Installation)  
50A, 80A 120A**

**Figure 4B**

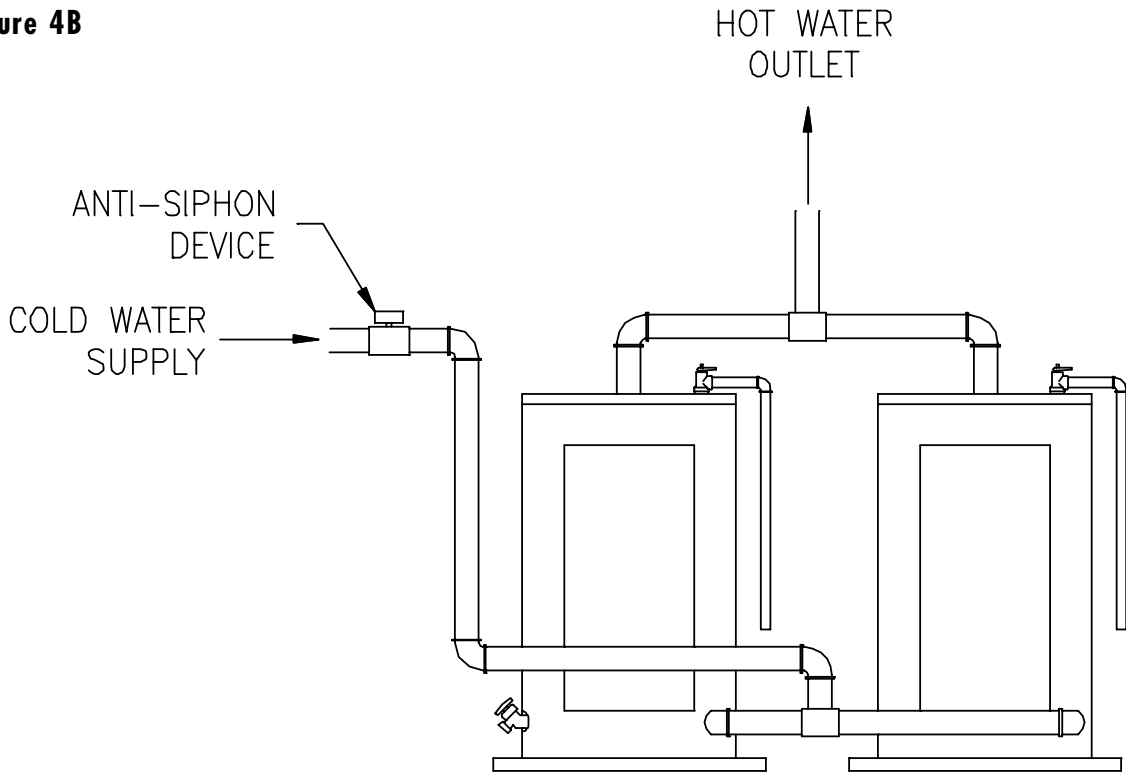

**(Dual Water Heater Installation)  
6A, 12A, 20A, 30A 40A**

**Electrical Connections**

Before any electrical connections are attempted, be sure the water heater is full of water and that the manual shut-off valve in the cold water supply line is open. Heating elements, which have been energized for a very short period of time, can be damaged (burned-out) if they are not completely immersed in water. The warranty does not cover burned-out heating elements. Check the rating plate and wiring diagram before proceeding. This electric water heater was manufactured and wired in accordance with Underwriters Laboratories testing approval requirements. The temperature-limiting device is of the manual reset, trip-free type and has been factory installed to interrupt all ungrounded power supply conductors in the event of thermostat failure. The plumbing supplier in your area ordered this water heater wired at the factory to comply with existing area codes, but local utility codes may require or allow other circuitry. Consult your local power company to determine the correct electrical hook-up in order to meet local utility and building codes and in order to obtain the most economical rates. All electrical connections to elements, thermostats, contactors, fuses (certain models), and transformers have been made at the factory. **DO NOT** alter any of the internal wiring. Wiring connections may loosen during shipment. Check all connections for tightness.

To make the wiring connections to a power supply, follow the steps below.

- A) Open the cover door of the control box.
- B) Bring the power leads from an adequately fused disconnect switch (not furnished with the water heater due to varying state and local codes) and connect to the terminal block. Local ordinances and/or utility company may require an increase in the gauge size of the wiring for conditions where long wiring lengths exist.

- C) This water heater must be properly grounded. A ground lug is provided within the electrical control box for connection to a properly sized ground. (See wiring diagram for minimum required ground size. The wiring diagram is located on the inside door of the control box).
- D) Close the cover door of the control box.

**Heating Elements**

To replace heating elements, disconnect power to the water heater, drain tank and replace element. To remove a heating element, use a screw type element wrench (1 1/2" or 2 3/8") available from most supply houses. **DO NOT** over-tighten the new element, as this will cause distortion in the new element gasket. Once the element has been replaced, follow the instructions "To Fill The Water Heater". It is imperative that the water heater is full before power is restored to the heating elements.

Amperage Chart									
kW Input	208V		240V		277V	380V	415V		480V
	1Ø	3Ø	1Ø	3Ø	1Ø	3Ø	3Ø	1Ø	3Ø
3	15	-	13	-	11	-	-	7	-
6	29	17	25	14	22	9	8	8	12
9	43	25	38	22	32	14	13	13	19
12	58	33	50	29	43	19	17	17	25
13.5	65	38	56	32	49	21	19	19	28
15	72	42	63	36	54	23	21	21	31
18	87	50	75	43	65	28	25	25	38
24	115	67	100	58	87	37	34	34	50
27	130	75	113	65	97	41	38	38	56
30	144	83	125	72	108	46	42	42	63
36	173	100	150	87	130	55	50	50	75
45	216	125	188	108	162	69	63	63	94
54	260	150	225	130	195	83	75	75	113
81	390	225	338	195	293	123	113	169	98

Water heaters with amperage draw of 120 AMPS or more require factory installed internal fusing to comply with Underwriters Laboratories requirements.

## Compact ASME

### GPH Recovery Capacities

kW Input	Temperature Rise								
	40°F	50°F	60°F	70°F	80°F	90°F	100°F	120°F	140°F
3	31	25	21	18	16	14	13	11	9
6	62	50	41	35	31	28	25	21	18
9	93	74	62	53	47	41	37	31	27
12	124	99	83	71	62	55	50	41	35
15	155	125	103	89	78	69	62	52	44
18	186	149	124	106	93	83	74	62	53
24	248	199	164	142	124	110	99	83	71
27	279	223	186	160	140	124	112	93	80
30	310	248	207	177	155	138	124	103	89
36	372	298	248	213	186	165	149	124	106
45	465	372	310	266	233	207	186	155	133
54	558	447	372	319	279	248	223	186	160
81	837	671	558	479	419	372	335	279	240

Multiply kW input by 3,412 to determine Btu/hr input: Example: 54kW x 3412 = 184,248 Btu's

#### Recovery Computation Formula

$$\text{GPH} = (\text{watts} \times 3.412) / (8.25 \times \text{Temp. Rise})$$

### GENERAL OPERATION

Before closing the switch to allow electric current to flow to the water heater, make certain that the water heater is full of water and that the cold water inlet valve is open. Complete failure of the heating elements will result if they are not totally immersed in water at all times. When the switch is closed, the operation of this electric water heater is automatic. The temperature control knob located on the side on the control box is factory preset to 120°F (49°C). Care must be taken whenever using hot water to avoid scalding injury. Certain appliances require high temperature hot water (such as dishwashers and automatic clothes washers).

#### ▲ CAUTION

Scalding may occur within five (5) seconds at a temperature setting of 135°F (57°C).

### TO FILL THE WATER HEATER

1. Close the water heater drain valve by turning the knob clockwise.
2. Open the cold water supply shut-off valve.
3. Open several hot water faucets to allow air to escape from the system.
4. When a steady stream of water flows from the faucets, the water heater is filled. Close the faucets and check for water leaks at the water heater drain valve, combination temperature and pressure relief valve and hot and cold water connections.
5. Reconnect power supply to water heater.

### TO DRAIN THE HEATER

Should it become necessary to completely drain the water heater, make sure you follow the steps below:

1. Disconnect the power supply to the heater. Consult the plumbing professional or electric company in your area for service.
2. Close the cold water supply shut-off valve.
3. Open the drain valve on the water heater by turning the knob counter-clockwise. The drain valve has threads on the end that will allow connection to a standard hose coupling.
4. Open a hot water faucet to allow air to enter the system.

To refill the water, refer to "TO FILL THE WATER HEATER".

### Thermostat Adjustment

To adjust the water temperature, locate the temperature control dial on the right side of the control box. To increase the water temperature, rotate the temperature control dial clockwise see Figure 5. The thermostat(s) or temperature control dial has been factory preset to approximately 120°F (49°C).



**▲ DANGER**  
 Hotter water increases the risk of scald injury. Scalding may occur within five (5) seconds at a temperature setting of 135°F (57°C). To protect against hot water injury, install an anti-scald tempering valve in the water system. This valve will reduce point of discharge water temperatures by mixing cold and hot water in branch water lines. A licensed plumbing professional or local plumbing authority should be consulted.

**Note:** This water heater is equipped with an energy cut out device to prevent overheating. Should overheating occur, turn off the electrical supply to the water heater and contact a qualified service technician.

1. Annually, check the operation of the thermostat(s).
2. Bi-annually, check the seal around the heating elements for leaks. If there is any sign of leaking, disconnect the power supply to the water heater and contact the plumbing professional that installed this water heater or a qualified service technician.
3. At least once a year, check the combination temperature and pressure relief valve to ensure that the valve has not become encrusted with lime. Lift the lever at the top of the temperature and pressure relief valve several times until the valve seats properly without leaking and operates freely.

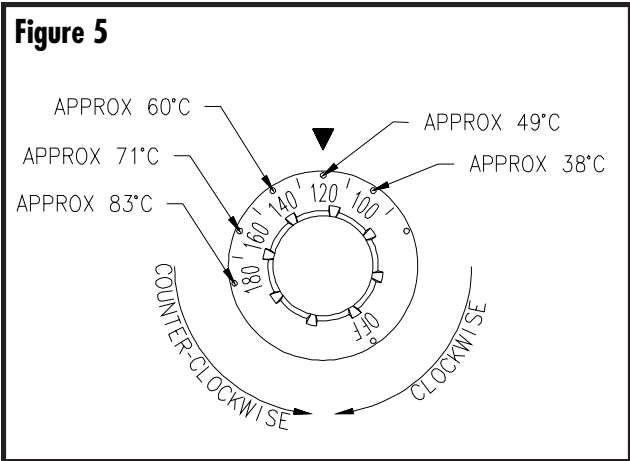

**▲ WARNING**  
 When lifting the lever of temperature and pressure relief valve, hot water will be released under pressure. Be certain that any released water does not result in bodily injury or property damage.

4. If the combination temperature and pressure relief valve on the appliance discharges periodically, this may be due to thermal expansion in a closed water supply system. Contact the water supplier or local plumbing inspector on how to correct this situation. Do not plug the combination temperature and pressure relief valve outlet for any reason.
5. Monthly, drain the heater through the drain valve until the water runs clear to remove silt and sediment.

**▲ WARNING: THIS WATER MAY BE HOT.**

**MAINTENANCE**

**IMPORTANT**  
 The water heater should be inspected at a minimum of annually by a qualified service technician for damaged components. **DO NOT** operate this water heater if any part is found damaged.

6. A sacrificial anode rod has been installed to extend tank life. The anode rod should be inspected periodically (every 2 years) and replaced when necessary to prolong tank life. Water conditions in your area will influence the time interval for inspection and replacement of the anode rod. Contact the plumbing professional who installed the water heater or the manufacturer listed on the rating plate for anode replacement information. The use of a water softener may increase the speed of anode consumption. More frequent inspection of the anode is needed when using softened (or phosphate treated) water.
7. If this water heater is equipped with fuses, before removing any fuse, disconnect all the power to the water heater. Open the control box door and replace fuses according to the size indicated on the wiring diagram affixed to the inside of the control box door.

Shut off the electric power whenever the water supply to the water heater is off. Shut off the electric power and water supply, drain the heater completely to prevent freezing whenever the building is left unoccupied during the cold weather months. In order to ensure efficient operation and long tank life, drain the water heater at least once a month through the drain valve until the water runs clear. Failure to do this may result in noisy operation and lime and sediment build-up in the bottom of the tank. Check the temperature and pressure relief valve to ensure that the valve has not become encrusted with lime. Lift the lever at the top of the valve several times until the valve seats properly without leaking and operates freely. The following maintenance should be performed by qualified service technician at the minimum periodic intervals suggested below. In some installations, the maintenance interval may be more frequent depending on the amount of use and the operating condition of the water heater. Regular inspection and maintenance of the water heater will help to ensure safe and reliable operation.

**▲ CAUTION**  
**FOR YOUR SAFETY, DO NOT ATTEMPT TO REPAIR THERMOSTAT(S), HEATING ELEMENTS, OR ELECTRICAL WIRING. REFER SUCH REPAIRS TO A QUALIFIED SERVICE TECHNICIAN.**

Contact your local plumbing supplier or plumbing professional for replacement parts or contact the company at the address displayed the rating plate of the water heater.

## SERVICING GUIDE

This “Servicing Guide” section of this Installation and Operation Installation manual is provided for the purpose of improving the effectiveness and the efficiency of servicing this water heater. This information is intended to assist qualified service personnel. Servicing of this water heater may require knowledge of electrical testing instruments. If you are unfamiliar or unsure of the electrical circuits testing instruments, consult a qualified electrician.

This section of these Installation and Operation Instructions is not intended for use as a troubleshooting guide. For troubleshooting instructions please contact the supplier from whom this water heater was purchased or the manufacturer listed on the rating plate.

This water heater has two distinct electrical systems. One system connects the electrical power to the heating elements, while the other system controls the water heater operation. The electrical contactors interconnect these two systems. In order to clearly illustrate the electrical circuits, two wiring diagrams are provided. These diagrams are labeled as the: “Power Circuit Wiring Diagram” and the “Control Circuit Wiring Diagram” and they are attached to the surface of the panels inside the water heater control cabinet.

### Control Circuit Description

This description will explain certain aspects of the control circuit. The control circuit operates with 120 VAC electrical service. This voltage is provided by the multi-tap transformer which has the primary coil connected to the field wiring that is serving the water heater. The Transformer, the Water Heater Thermostat, the Hi-Limit Temperature Control, and the Contactor Coil are always included in the Control Circuit.

Referring to the “Control Circuit Wiring Diagram”, the contactor coil is energized when the Thermostat senses a need for heating. Electrical current to the contactor coil will be interrupted when the water temperature is sufficient to satisfy the temperature limits of the either the Thermostat or the Hi-Limit Control. The Hi-Limit Control is provided with manual reset buttons.

Certain other control components are available as “Optional”. When these optional components are installed with the water heater, the control circuit wiring diagram accordingly will include these components. The optional equipment available from the manufacturer includes the following:

- High Water Pressure Switch
- Low Water Pressure Switch
- Low Water Level Switch
- Alarm Horn
- Heating Element Sequencers
- Electrical Door Lock

## Optional Components

### High and Low Water Pressure Controls

These controls interrupt the electrical current to the contactor coil when the pressure settings are exceeded. The operation and setting of these controls are described in the manual provided by the control manufacturer. This manual is included with the water heater Installation and Operating Instruction manual provided by the manufacturer.

The pressure settings for these controls are adjustable. These controls are specified for use when the installation has unique pressure requirements that must be safeguarded. Therefore, before adjusting the pressure values, it is recommended that you consult the person responsible for the facility that the water heater is servicing.

The electrical connections are referenced in the Control Circuit Wiring Diagram and in the pressure control manual provided by the control manufacturer. Refer to these instructions when servicing the controls.

The following unusual situations will give reason for the pressure controls to interrupt the electrical current to the coil of the contactor:

- Upon installation or occasions of re-starting heater operation, if the inlet supply line is closed (i.e. a shut-off valve), the high pressure limit may be exceeded due to reasons of thermal expansion of the water.
- If during the operation of the water heater the inlet line is closed (i.e. a shut-off valve), a low pressure condition can develop when water is allowed to exit through the outlet connection.
- If during the operation of the water heater the inlet line is closed (i.e. a shut-off valve), a low pressure condition can develop when water is removed through the water heater drain valve.

### Low Water Level Control

This control will interrupt the electrical current to the contactor coil when a low water level condition is sensed inside the water heater tank. When the low water level condition is corrected the control will automatically sense the new situation and electrical current will again energize the contactor coil and normal water heater operation will be resumed.

To remove the low water level control from the tank you must first loosen the control by un-threading it from the tank fitting and then rotating the control until the arrow printed on the side of the hex fitting is pointing downward. Refer to (Figure 6) for clarification. This will enable the float orientation to align itself with the opening in the tank-fitting.

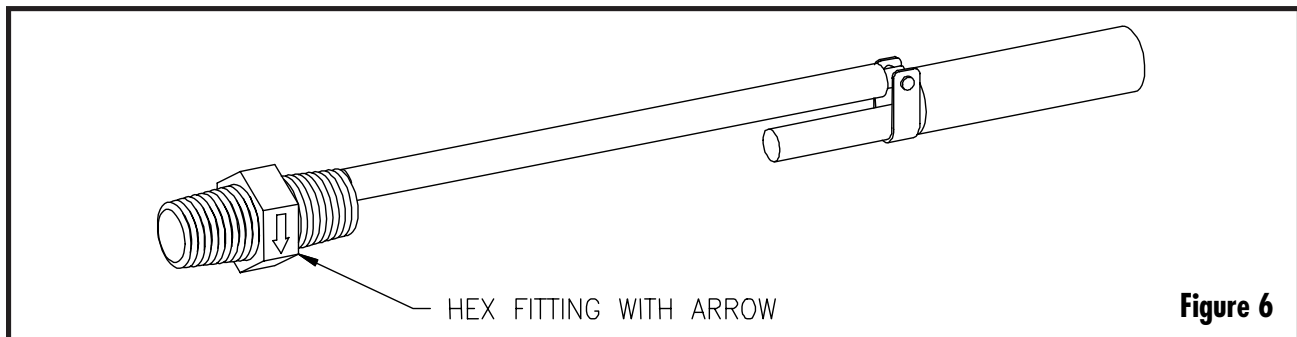
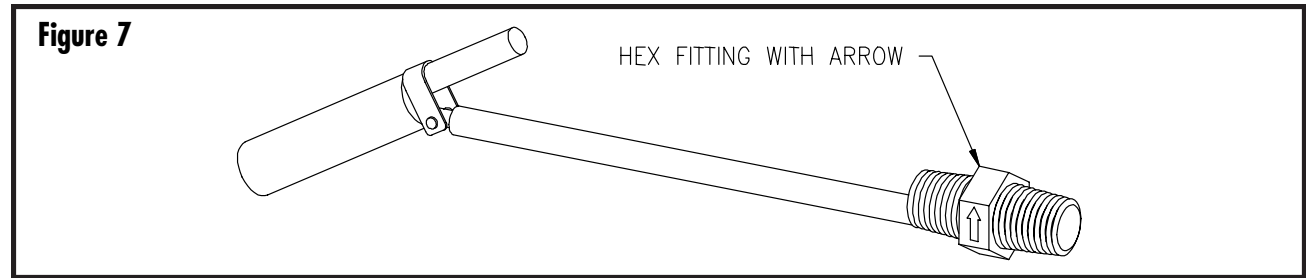

Figure 6

When installing the control refer to the direction of the arrow on the hex and ensure that it is pointing upwards. If it is not pointing upward, the control switch will not activate when the tank is refilled with water. Refer to Figure 7 for clarification.

thereby, staging the three contactors over the 40 second time period. The staging occurs in a similar manner for applications having more than three contactors.



**Alarm Horn**

The Alarm Horn is an option specified when the installation desires an audible signal to immediately sound an alert when the water heater operation is interrupted for certain faults. Referring to the control circuit wiring diagram, the alarm will activate when any one of the following events occur:

- The Hi-Limit Control has been tripped
- The High Water Pressure Control senses excessive pressure
- The Low Water Pressure Control senses insufficient pressure
- The Low Water Level Control senses an insufficient quantity of water

The alarm will sound only for the options specified (i.e. if a low water level control is not specified then the alarm will not recognize a low water level condition). Referring the Control Circuit Wiring Diagram, observe the horn relay that is employed to correctly apply the horn to the control circuit.

The following unusual situations will give reason for the alarm to sound:

- If a High Pressure Control is installed, upon installation of the water heater or occasions of re-starting water heater operation, if the inlet supply line is closed (i.e. a shut-off valve), the high pressure may be exceeded due to reasons of thermal expansion of the water.
- If a Low Pressure Control is installed and if during the operation of the water heater the inlet line is closed (i.e. a shut-off valve), a low pressure condition can develop when water is allowed to exit through the outlet connection.
- If a Low Pressure Control is installed and if during the operation of the water heater the inlet line is closed (i.e. a shut-off valve), a low pressure condition can develop when water is removed through the water heater drain valve.

**Heating Element Sequencers**

Heating element sequencers are available in order to stage the activation of the heating elements thereby, reducing the inrush current to the water heater. The sequencers will control one or two contactor coils depending upon the heater voltage, phase, and kW.

One contactor will be energized immediately when there is heating demand, the second contactor, controlled with a sequencer, will be activated approximately 20 seconds later, and third contactor will be activated in another 20 seconds

Refer to the Control Circuit Wiring Diagram for the specific application being serviced.

**Note:** On the occasion of servicing the water heater where frequent restarts in a short time interval are encountered (i.e. on, off, on, etc.), the timing sequences will not begin until the sequencers have experienced a time interval to reset.

**Electrical Door Lock**

An electrical door lock is offered in order to secure the access to the water heater control cabinet. This device will lock the control cabinet door when the 120 VAC control circuit voltage is applied to it.

**Note:** once the door is opened, the heater can be re-energized, if necessary, for service diagnosis.

**Power Circuit Description**

The Power Circuit Wiring Diagram illustrates the electrical connections from the incoming power supply through the circuit to the electrical elements. The power circuits are available with internal circuit fusing and without internal circuit fusing.

Refer to the water heater power circuit wiring diagram attached to the inside panel of the control cabinet for the specific connections of the heater being serviced. The power circuit components and supporting information that appear on the wiring diagram include the following:

- Field wiring connection via terminal block or other connection point
- Fuse block with amperage rating displayed (when provided)
- Contactors with amperage ratings displayed
- Electrical elements with voltage and wattage ratings displayed
- Water heater total amperage draw is displayed

# Notes