

INDIRECT PLATE AND FRAME WATER HEATER

JOB NAME _____
 LOCATION _____
 ENGINEER _____
 WHOLESALER _____
 CONTRACTOR _____
 MODEL NO. _____
 TYPE GAS _____
 EQUIPMENT TAG _____
 NOTES _____

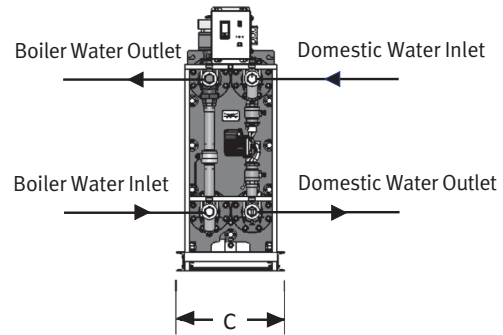
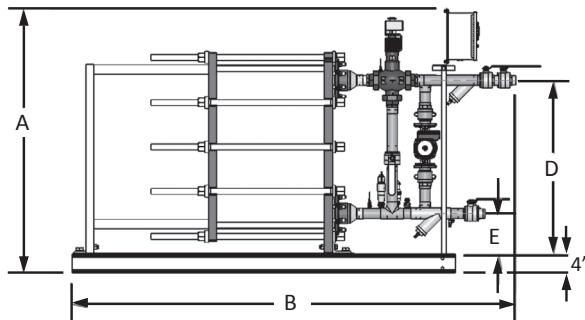

Indirect Plate and Frame Dimensions and Specifications

| Model Number | A | B | C | D | E | Water Connections |
|--------------|-----|------|-----|-----|----|-------------------|
| IPW015DW | 50" | 66" | 17" | 31" | 6" | 1-1/4" |
| IPW030DW | 50" | 74" | 17" | 31" | 6" | 1-1/4" |
| IPW050DW | 50" | 87" | 17" | 31" | 6" | 2" |
| IPW070DW | 50" | 97" | 17" | 31" | 6" | 2" |
| IPW090DW | 56" | 101" | 23" | 37" | 6" | 2" |
| IPW105DW | 56" | 107" | 23" | 37" | 6" | 2-1/2" |
| IPW120DW | 56" | 107" | 23" | 37" | 6" | 2-1/2" |

Standard Features

- ASME Double Wall Heat Exchanger
 - 316L Stainless Steel
 - 150 psi Working Pressure
- Digital Display
 - Set Point Range 90°F to 180°F
- Advance Temperature Control
- Modulating Control Valve
- Scale Reduction Pump
- Automatic Air Vent
- ASME Temperature and Pressure Relief Valve
 - 210°F and 150 psi
- Adjustable High Limit
- Wye Strainers
- Isolation Valves
- Modbus Communication
- 5 Year Limited Warranty (See Warranty for Details)
- 1 Year Parts Warranty (See Warranty for Details)