

STORAGE TANK INSTALLATION and OPERATION MANUAL



LOW LEAD CONTENT



Lochinvar[®]
HIGH EFFICIENCY BOILERS & WATER HEATERS

⚠ WARNING

The information contained in this manual is intended for use by qualified professional installers, or service technicians. Consult your local expert for proper installation or service procedures.

Save this manual for future reference.

Contents

CONTENTS.....	2	Drain	7
HAZARD DEFINITIONS.....	2	Completing the installation	7
1. GENERAL INFORMATION.....	3	3. OPERATION	8
Tank construction	3-4	Startup procedure	8
2. INSTALLATION.....	5	Shutdown procedure.....	8
Transporting and unpacking the unit.....	5	4. INSPECTION	9
Examining the unit	5	5. MAINTENANCE	10
Anchoring the unit.....	5	Flushing the tank	10
Recommended service clearances	5	Cleaning the tank.....	10-11
Connecting the hot water source.....	5-6	Magnesium anode rod inspection.....	12
Cold water supply	6	Water piping and valve replacement	12-13
Hot water outlet	6	Temperature and pressure gauge replacement.....	13
Mixing valve	6	Notes	14-15
Aquastat / bulbwell	7	Revision Notes	Back Cover
Piping the relief valve	7		

Hazard definitions

The following defined terms are used throughout this manual to bring attention to the presence of hazards of various risk levels or to important information concerning the life of the product.

⚠ DANGER

DANGER indicates an imminently hazardous situation which, if not avoided, will result in death or serious injury.

⚠ WARNING

WARNING indicates a potentially hazardous situation which, if not avoided, could result in death or serious injury.

⚠ CAUTION

CAUTION indicates a potentially hazardous situation which, if not avoided, may result in minor or moderate injury.

CAUTION

CAUTION used without the safety alert symbol indicates a potentially hazardous situation which, if not avoided, may result in property damage.

NOTICE

NOTICE indicates special instructions on installation, operation, or maintenance that are important but not related to personal injury or property damage.



Hot Water Can Scald!

- Water heated to temperatures for clothes washing, dish washing, and other sanitizing needs can scald and cause permanent injury.
- Children, elderly, and infirm or physically handicapped persons are more likely to be permanently injured by hot water. Never leave them unattended in a bathtub or shower. Never allow small children to use a hot water tap or draw their own bath.
- If anyone using hot water in the building fits the above description, or if state laws or local codes require certain water temperatures at hot water taps, you must take special precautions:
 - Use lowest possible temperature setting.
 - Install some type of tempering device, such as an automatic mixing valve, at hot water tap or water heater. Automatic mixing valve must be selected and installed according to valve manufacturer's recommendations and instructions.
- Water passing out of drain valves may be extremely hot. To avoid injury:
 - Make sure all connections are tight.
 - Direct water flow away from any person.

Protection Must Be Taken Against Excessive Temperature and Pressure!
--Installation of a Temperature & Pressure (T&P) relief valve is required.

1 General information

The following chart (Table 1A) details the relationship of water temperature and time with regard to scald injury and may be used as a guide in determining the safest water temperature for your applications.

Table 1A Approximate Time / Temperature Scald Chart

APPROXIMATE TIME / TEMPERATURE RELATIONSHIPS IN SCALDS	
120°F	More than 5 minutes
125°F	1 1/2 to 2 minutes
130°F	About 30 seconds
135°F	About 10 seconds
140°F	Less than 5 seconds
145°F	Less than 3 seconds
150°F	About 1 1/2 seconds
155°F	About 1 second

⚠ WARNING

- Before using product, read and understand instructions.
- Save these instructions for future reference.
- All work must be performed by qualified personnel trained in the proper application, installation, and maintenance of the water systems in accordance with all applicable codes and ordinances.
- To prevent serious burns, wear heat resistant gloves when handling hot equipment.

Failure to follow this warning could cause property damage, personal injury, or death.

This manual is intended to cover installation, operation, and maintenance procedures for Lochinvar's Hot Water Storage Tank. Some storage tanks are built to meet customer specifications. Instructions may not be specific to every system.

If questions are not answered by this manual, or if specific installation, operation, and/or maintenance procedures are not clearly understood, contact Lochinvar for clarification before proceeding.

Most Hot Water Storage Tanks are designed for indoor use only, unless otherwise constructed by design specifications. It should be located on a level surface (no more than one-half degree of slope), capable of supporting the total weight of the unit when filled to capacity.

The unit should be mounted to the floor following applicable architectural and local code requirements for the specific installation site. **NOTE:** Tanks do not come standard with floor tie downs. Seismic tie downs are available upon request.

The high quality enamel paint, applied to the jacket of the unit, will provide years of protection against corrosion. If it is necessary to clean the outside of the unit, a mild cleaning agent should be used that will not damage the paint.

For all piping connections, the use and/or type of joint compound or sealer on the joints should be determined by referring to local codes, accepted standards, and/or the requirements of the installing contractor.

Tank construction

Hot Water Storage Tanks are pre-engineered and pre-assembled complete with all fittings. And like every Lochinvar product, they are thoroughly tested to ensure proper performance from the moment they are installed.

Gallon Capacities -- Lochinvar tanks are available in gallon capacities from 120 to 5000 gallons. Standard construction tanks from 120 to 940 gallons are maintained in regular inventory. Tanks over 1000 gallons are custom manufactured per order.

Tank Orientation -- Lochinvar tanks are available in vertical or horizontal orientation.

Tank Lining -- Lochinvar tanks are available in glass (standard) or cement (optional) linings, and unlined.

ASME -- All Lochinvar storage tanks are constructed per ASME Section IV requirements, or Section VIII.

Pressure Rating -- Lochinvar tanks are available in 125 psi working pressure (standard) or 150 psi working pressure (optional).

Cathodic Protection -- All glass lined tanks are equipped with magnesium anodes to provide protection against corrosion.

1 General information

Manway - A 12" x 16" manway is provided as an option on glass lined tanks and is standard on cement lined tanks. Four by six inch (4" x 6") hand holes are available on tanks under 300 gallons. Manways may not be installed on tanks under 30" diameter.

Jacketing -- Lochinvar tanks are available as "Bare", having no jacket or insulation.

Tanks with a round sheet metal jacket are insulated with a 2" thick foam mixture that has an R value of R-16. Square sheet metal jacketed tanks are insulated with a 3 1/2" thick fiberglass wrap that has an R value of R-13. **These tanks are for indoor installation only.**

Outdoor rated tanks are available with 2" thick foam insulation with no exposed metal surfaces. All jacketed storage tanks meet the energy efficiency requirements of the latest edition of ASHRAE 90.1.

Relief Valve Tapping -- A tapping is provided for the installation of a field supplied ASME safety relief valve.

Hot Water Recirculation Tappings -- Lochinvar storage tanks will have two (2) tappings on the tank to provide recirculation piping between the tank and a hot water source.

These tappings may be ordered in custom sizes, either threaded or flanged. Extra tappings are also available upon request.

Hot Water Outlet -- A Hot Water Outlet Tapping is positioned on the top of the tank for connection to the building system.

This tapping may be ordered in custom sizes, either threaded or flanged. Extra tappings are also available upon request.

Drain -- A tapping or drain pipe will be connected to a low point on the tank for drainage.

Temperature and Pressure Gauge (optional) -- Lochinvar tanks may be fitted with an optional temperature and pressure gauge.

Aquastat Bulbwell -- All Lochinvar tanks are provided with a bulbwell for the location of control sensors.

Five-Year Limited Tank Warranty -- Provides warranty protection against tank failure (see warranty for details).

One-Year Limited Warranty -- Parts and accessories (see warranty for details).

⚠ WARNING

Areas of potential danger:

1. All water lines, joints, and valves.
2. All power connections and cables.
3. If the unit has been in operation, allow the water in the heater and all components and surfaces (tank surface, water piping, etc.,) to cool before starting the procedure.
4. Assure that all power to associated water heating equipment has been shut off and disconnected before attempting any procedures.
5. Assure that all incoming and outgoing water lines have been shut off at the manual shutoff valves.

⚠ WARNING

Heated water presents situations that can be very dangerous due to the fact they are under pressure and at very high temperatures. To avoid possible injury or death, use common sense and follow all accepted and recommended procedures when performing installation, operation, and maintenance procedures.

⚠ WARNING

The combination of electricity and water can pose a very dangerous situation. Assure that all power has been shut off / disconnected before attempting any installation or maintenance procedures.

2 Installation

Transporting and unpacking the unit

Each jacketed Lochinvar Hot Water Storage Tank is crated as necessary at the factory. The crating is designed to provide protection for the unit during transportation, and to provide a safe means by which to lift and move the unit with a fork lift or hand truck.

Examining the unit

After the unit has been uncrated and set in place, it should be carefully examined to assure the tank has not been damaged during shipping. If any evidence of damage is detected that could affect the safe operation of the unit, contact Lochinvar, LLC., or your authorized sales representative, to report the damage and to receive instructions on how to proceed.

After the unit and all components have been inspected for damage, it is suggested that all optional or independent pressure and temperature control components be checked to assure that they meet or exceed design specifications. If any discrepancy is found, contact Lochinvar, LLC., or your authorized representative, before proceeding with the installation.

Anchoring the unit

The unit should be anchored to the floor, following applicable architectural / local code requirements, or accepted standards for the specific installation site. The unit should be installed in a location with sufficient clearance for service and repair.

Check local codes for Seismic anchoring requirements. If further assistance is needed, call the Lochinvar Technical Service Department and request a Seismic Report.

On horizontal tanks, the saddles should be located 6" to 12" from the head/shell seam. Both saddles must be placed using the same dimensions (FIG. 2-1). If there are tappings in the recommended space or if there are any concerns about the proper location for the saddles, please contact the manufacturer.

Figure 2-1_Saddle locations

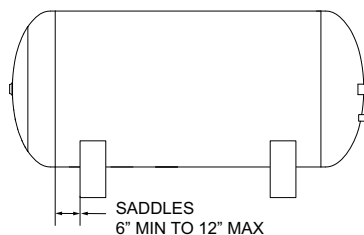

Recommended service clearances:

- 24 inches around the magnesium anode rod(s)
- 24 inches around the manway or hand hole

Connecting the hot water source

WARNING

Before making any connections of water inlet or outlet to the unit, assure that all piping is clean and free of foreign material or scale. This can usually be accomplished by “blowing out” the pipe. Any foreign material or scale entering the unit can adversely affect operation and performance.

The two (2) tappings on the lower side of a vertical tank or the two (2) tappings on the bottom of a horizontal tank shall provide recirculation between the tank and the water heating source. See example piping diagram between a storage tank and an indirect gas fired water heater (FIG’s 2-2 and 2-3).

The upper side tapping on a vertical storage tank is the tank’s water recirculation inlet. The lower side tapping on a vertical storage tank is the tank’s water recirculation outlet. On a horizontal tank, either recirculation tapping can be used for recirculation inlet or outlet.

NOTICE

See the Water Heater’s Installation and Operation manual for specific piping diagrams that match the inlet / outlet water tappings on the tank to the inlet / outlet water tappings on the water heater. Tapping locations on the water heater may vary by product or manufacturer.

Figure 2-2_Vertical Tank Piping Diagram, Non-Condensing

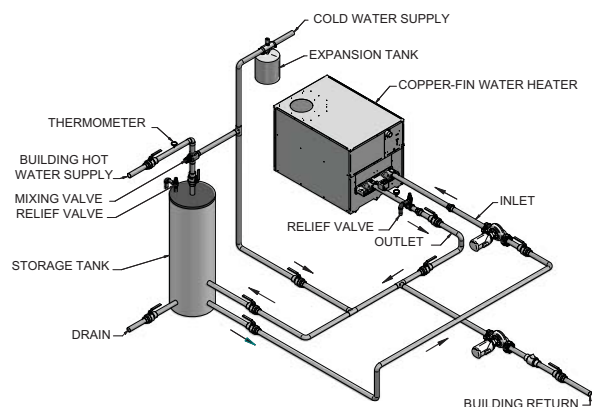

2 Installation

Figure 2-3_Horizontal Tank Piping Diagram - Non-Condensing

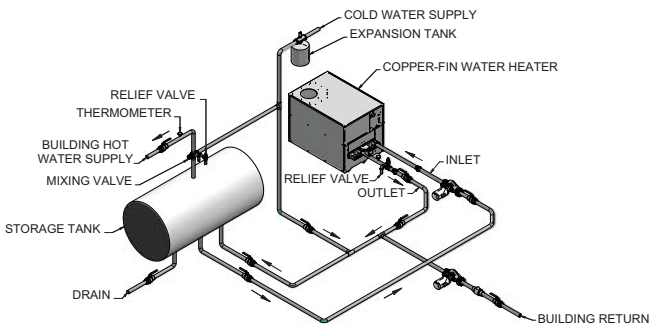
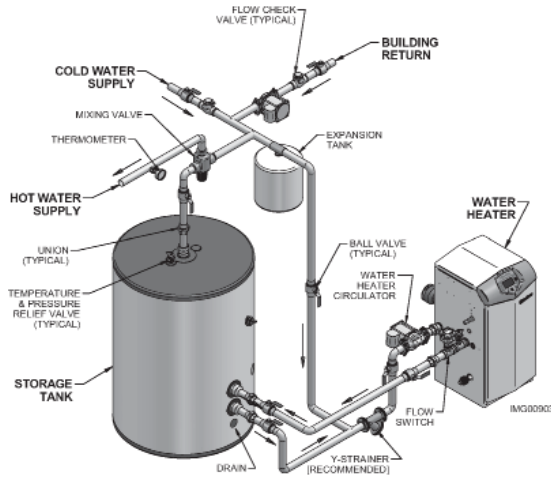

Figure 2-4_Vertical Tank Piping Diagram, Condensing



NOTICE

For **all** piping connections, the use and / or type of joint compound or sealer on the joint should be determined by referring to local codes, accepted practices, or the requirements of the installing contractor.

Cold water supply

The next step in the installation process is to connect the cold water supply to the recirculation piping between the heater(s) and the tank(s).

NOTICE

If the cold water supply to the system is equipped with an in-line check valve or backflow preventer, a suitable expansion tank must be installed in the cold water supply line.

The location of the cold water supply connection will vary based on the type of water heater installed. If a non-condensing water heater is installed, connect the cold water supply to the recirculation pipe on the water heater's outlet. This allows the cold water to mix with the stored water, so tempered water is recirculated back into the non-condensing water heater.

If a condensing water heater is installed, connect the cold water supply to the recirculation pipe on the water heater's inlet. This allows the cold water to enter the condensing water heater first for high-efficiency condensing operation.

Review the water heater's installation manual to confirm the ideal connection for the cold water supply.

Hot water outlet

The next step in the installation process is to connect the hot water system piping to the hot water outlet port. The hot water supply tapping is located on top of the tank.

A manual shutoff valve should be installed downstream on the hot water outlet line as an isolation device in case the unit must be disconnected from the system. The shutoff valve should be in the closed position and remain so until the installation is complete.

Mixing valve

Field supplied. An anti-scald mixing valve is recommended when storing domestic hot water above 115°F.

2 Installation *(continued)*

Aquastat bulbwell

Review the controls for the hot water source equipment. Some equipment or systems designs will require an independent aquastat (field supplied) to control the equipment. The aquastat may be surface mounted onto the sheet metal jacket of the tank or a nearby surface. The water sensing probe may be installed in the dry bulbwell supplied with all Lochinvar Hot Water Storage Tanks. The equipment may employ a water sensing thermistor. The thermistor would be installed into the dry bulbwell and wired back to the hot water equipment.

In installations with more than one water heater, more than one probe may need to be installed in the storage tank. A field supplied brass or stainless steel bulbwell may be installed to accommodate multiple sensing probes. The standard bulbwell has a bulb area depth of 2 15/16" and can accommodate a sensor/bulb that is 3/8" in diameter.

An optional "Super-Bulbwell" has a two chamber bulb area. The inner chamber depth is 3" and can also accommodate a 3/8" diameter sensor/bulb. The outer chamber has a 3 5/16" depth and can easily fit a 3/8" diameter sensor/bulb plus the wires or capillary tube from the inner chamber sensor/bulb. Contact Lochinvar customer service for information on special, oversized bulbwells.

Piping the relief valve **(Relief valve is field supplied)**

All Lochinvar Hot Water Storage Tanks are equipped with a relief valve tapping on the tank. The valve should be piped to a discharge line leading to a suitable drain. Piping the pressure relief valve to a suitable drain will prevent both water and heat damage to the unit, as well as reduce the risk of injury from released heated water. The pipe must be of adequate size to properly handle the capacity of the relief valve and discharge line.

Check local codes to assure compliance. If a check valve has been installed on the inlet water line, thermal expansion may take place causing build up of excessive pressure when the water is being heated. This expansion will cause the relief valve to open, releasing hot water to the discharge line. A properly sized expansion tank must be installed to protect the system from water expansion.

WARNING

Do not install a manual shut off valve between the relief valve and the discharge. Doing so could cause serious injury or death if the relief valve released and the manual valve was closed. This would cause excessive buildup of pressure in the storage tank which could result in an explosion.

Drain

The tanks' drain connection must be piped to a suitable floor drain. Brass drain cocks are acceptable. A brass full port ball valve is recommended to improve water flow.

Completing installation

Installation of the Lochinvar Hot Water Storage Tank is now complete. All documentation supplied with the unit should be passed along to maintenance personnel for future reference.

3 Operation

After all installation procedures have been completed, and all water piping to the energy source and power connections have been double checked, the unit is ready for operation. The following Startup Procedure focuses on the storage tank. Check the Installation and Operation Manual of the hot water source for additional startup and shutdown procedures.

Tank Pre-Start Flush

NOTICE

It is recommended that the tank be flushed before startup in order to clear the vessel of loose particles and material from the installation process. This is strongly recommended for cement lined tanks. To flush the tank, see “Flushing the storage tank” instructions in the “Maintenance” section of this manual.

Startup procedure

1. Assure that all manual shutoff valves are closed.
2. Slowly open the manual shutoff valve on the cold water supply line and the valves in the hot water source recirculation piping. Check to assure that there are not leaks at the valve or any joints. Allow the tank to fill with water. As the tank is filling, hold the relief valve open to allow air to bleed out of the tank. Hot water faucets at the highest location in the building should also be opened. This will speed the filling process. Make sure the tank is full of water and free of air.
3. Open the manual shutoff valves.
4. Turn on the recirculation pump between the water heater and the tank.

After the power to the pump is turned on verify that the pump is working. If the pump is an oil lubricated unit, verify proper oiling.

⚠ WARNING

Heated water presents situations that can be very dangerous because of the high temperatures and pressures. Use common sense and follow all accepted and recommended procedures when performing installation, operation, and maintenance procedures to avoid possible injury or death.

5. Follow the Startup procedure for the water heater to initiate a call for heat. Adjust the operating temperature control to the desired operating temperature and set the safety high limit.
6. As the unit is heating the water, carefully re-inspect water recirculation piping and the tank hot water outlet for signs of leakage.
7. After the unit has reached operating temperature, re-inspect all joints for signs of leakage. In addition, check all gauges and controls to verify that the water temperature and pressure are within design specifications.
8. The unit is now ready for normal operation.

Shutdown procedure

1. Turn off all power to the circulating pump and the hot water source controls.
2. Close all valves in the system in the following order:
 - the hot water outlet line;
 - the recirculation water piping
3. Relieve the pressure where possible.
4. After the system has cooled, drain the unit by opening the tank drain valve and holding the relief valve in the open position. This will prevent the formation of a vacuum and increase the drainage flow.
5. Proceed with the required maintenance or repairs.
6. After performing the required maintenance or repairs, return the unit to operation by following the Startup Procedure.

4 Inspection

The following table summarizes the recommended time intervals for inspections of the tank, components, water piping and power connections.

RECOMMENDED INSPECTIONS					
To Be Inspected	Time Interval				
	Per Manufacturer Specs	Weekly	Monthly	Quarterly	Annually
Circulating Pump	✓				
Gauges - Pressure & Temperature				✓	
Lines - Inlet, Outlet, & Return				✓	
Pressure Relief Valve	✓				
Shutoff Valves - Manual		✓			
Temperatures - Water & Operating				✓	
Thermometer			✓		
Magnesium Anode Rods					✓
Interior for Sediment or Scale					✓
Flush tank at six (6) month intervals			✓		

5 Maintenance

A new tank installation should have a regular inspection program set up. The first inspection should be within the first three months of operation. Once the tendency to accumulate sediment has been established, the inspection program can be modified to suit the water conditions. Typical inspection programs flush the tank at six-month intervals and clean the tank in yearly intervals.

Deliming solvents or acid type flush agents are not recommended for use in lined storage tanks. These chemical cleaners are usually designed for use in non-potable systems such as heating boilers. These chemicals may be aggressive and cause damage to the tank lining and deteriorate the magnesium anodes supplied in glass-lined storage tanks.



WARNING Hot water will be released under pressure. Avoid contact with the hot discharge water to prevent the risk of severe scald injury.

Flushing the storage tank

Since mineral accumulation occurs in an un-fired tank it will be in a soft sediment form. This soft sediment can be removed by a regular flushing of the lower portion of the tank.

To flush the tank, follow these steps:

1. Turn off electrical power to the circulating pump and any other tank accessories.
2. Close the valve on the hot water outlet on top of the storage tank.
3. Ensure that the drain located on the bottom of the tank is routed to a floor drain with adequate capacity to allow the tank to be flushed.
4. Open the drain valve and allow the incoming cold water to flush the soft sediment out the bottom of the storage tank. Use extreme caution, as the water exiting the tank drain may be very hot. Avoid contact with the hot discharge water to prevent the risk of severe scald injury.
5. Observe the color of the water initially discharged from the tank drain. This water will generally be milky or slightly discolored by the sediment discharge. Allow the drain to run until the water runs clear.
6. Close the drain valve on the tank.
7. Open the hot water outlet valve on top of the tank.
8. Open an adjacent hot water tap to purge any air that may have entered the storage tank during the draining process. Close the hot water tap if no air discharge is observed.
9. Turn on electric power to the circulating pump and other electrical components if necessary.
10. Observe tank and piping to ensure all components are functioning properly.

Cleaning the storage tank

The mineral accumulation in an un-fired tank will be in a soft sediment form that can be removed by a regular cleaning of the lower portion of the tank. Many tanks will have a hand hole or a larger manway to allow access to the interior of the tank for complete removal of accumulated sediment. An access opening to remove the manway or hand hole is provided in the exterior jacket. The sheetmetal jacket components are removed with hand tools. The opening will be in the bottom portion of a vertical tank and on the end of a horizontal tank (see FIG's 5-1 and 5-2 below).

Figure 5-1_Vertical Tank

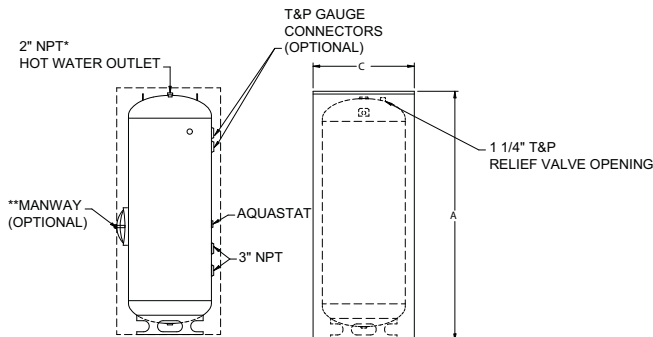

**Manway standard on cement and required on tanks with bundles 48" and larger.

Figure 5-2_Horizontal Tank

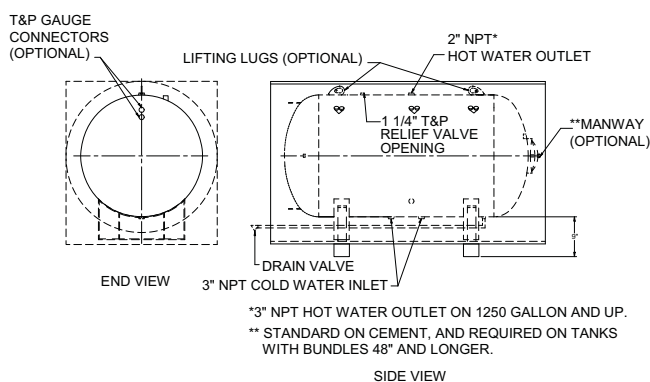

*3" NPT HOT WATER OUTLET ON 1250 GALLON AND UP.

** STANDARD ON CEMENT, AND REQUIRED ON TANKS WITH BUNDLES 48" AND LONGER.

SIDE VIEW

5 Maintenance *(continued)*

NOTICE

For this procedure, a new manway gasket or hand hole gasket should be acquired before beginning this procedure.

To clean the tank, follow these steps (reference FIG.'s 5-3 and 5-4):

1. Turn off electrical power to the circulating pump and other electrical components if necessary.
2. Close the valve on the hot water outlet on top of the storage tank and the cold water supply to the system.
3. Ensure that the drain located on the bottom of the tank is routed to a floor drain with adequate capacity to allow the tank to be drained.
4. Open the drain valve and open a vent to allow the air to enter the tank (manually opening the relief valve will usually accomplish this). Use extreme caution, as the water exiting the tank drain may be very hot. Avoid contact with the hot discharge water to prevent the risk of severe scald injury.
5. Allow the tank to drain completely.
6. Remove the jacket cover over the manway or hand hole. Remove the bolt(s) securing the tank access opening. Use a flashlight to observe the sediment collected in the tank.
7. Use hand tools to remove all sediment from the interior of the tank. Use care not to damage the interior lining of the storage tank.
8. Use a water hose to flush the remaining sediment from the interior surfaces of the tank and ensure that all debris is removed. Scale or sediment allowed to reach the potable system can foul valves, pumps, strainers, and other water fixtures. Ensure that the tank interior is clean before refilling the vessel.
9. Install a new gasket on the manway or hand hole to prevent any possible leaks. Tighten the gasket properly to prevent leaks.

CAUTION

Over tightening can result in cutting the gasket and allowing a water leak to occur.

10. Replace the jacket cover over the manway or hand hole.

11. Close the drain and open the cold water supply and hot water outlet. If the relief valve was used for a vent ensure that it is now closed. Open the closest hot water valve to allow the air in the tank to vent as water enters the vessel. Close the valve opened for a vent when water flows from the valve.
12. Check the manway or hand hole and all related piping for any water leaks.
13. Turn on electric power to the circulating pump and other electric components if necessary.
14. Turn on the water heater.
15. Open the valves in the hot water source recirculation piping.
16. Observe tank and piping to ensure all components are functioning properly.

5 Maintenance

Magnesium anode rod inspection

Glass lined storage tanks have a magnesium anode(s) to provide cathodical protection of the lining and minimize corrosion. Aggressive water conditions in some areas of the country may accelerate the deterioration of the anode(s). The anode(s) should be periodically removed and inspected to determine if replacement is necessary.

The tank must be valved off from the system and fully drained to remove an anode for inspection. Anodes are supplied in threaded fittings on the top head of small vertical storage tanks. Top mounted anodes may be accessed by removing the plastic plugs in the jacket top. Medium sized tanks with round jackets provide an opening for individual anode rod access. Large vertical storage tanks and horizontal storage tanks have multiple anodes installed in threaded tappings along the length of the tank. These anodes may be accessed by removing a jacket panel and/or corner post corresponding to the mounting point of the anodes. Adequate service clearance is required to allow removal of an anode. Field insulated tanks should make considerations for access to the anode rods.

Figure 5-3_Horizontal Storage Tank w/Anodes

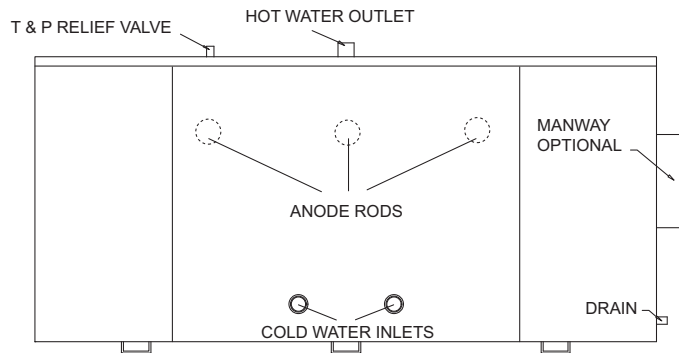

Service Note:

Replace the anode(s) when more than six (6) inches of the core wire is exposed at either end of the rod.

Figure 5-4_Vertical Storage Tank w/Anodes

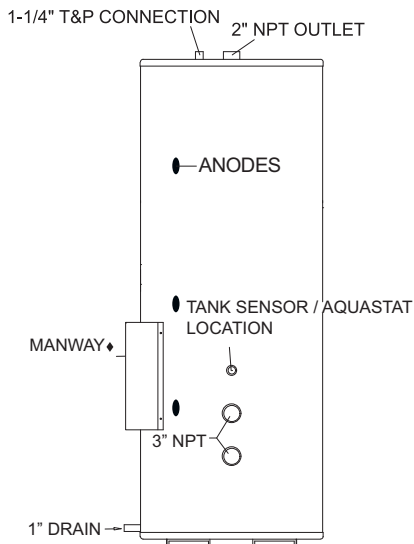

NOTICE

Anode rods showing excessive decomposition may indicate electrolysis. An earth ground should be attached to the vessel to divert stray current and prevent tank damage.

Water piping and valve replacement

If any of the inlet, outlet, return lines, or shutoff valves are damaged and must be replaced, follow the steps outlined in this section.

WARNING

The combination of electricity and water can pose a very dangerous situation. Turn off / disconnect all electric power before attempting any maintenance procedure.

1. Follow Steps 1 through 5 of the Shutdown Procedure on page 8 to take the hot water source off-line before attempting to replace damaged lines or shutoff valves.

WARNING

While it might seem feasible to replace inlet and outlet water lines, and shutoff valves without shutting down the entire unit, it is not advised. Unless the unit is completely shut down, and the water and the energy source are isolated from the system, failure of a manual shutoff valve during the replacement process could result in serious injury.

2. Make certain that the hot water source recirculation valves and hot water outlet valves have been shut off; that the tank has been completely drained; that the pressure has been bled from both the water and energy source systems; and that all components and surfaces have cooled.
3. Carefully break the joint between the unit and the line or valve to be replaced.
4. Remove the section of the line or valve to be replaced.
5. Replace the damaged section of the line or valve.
6. Reconnect the line or valve to the unit. Follow recommendations contained in the manufacturer's documentation, local codes, or accepted contractor practices as to the use and /or type of joint compound or sealer at the connections.
7. Follow the Startup Procedures on page 8 to place the unit back on-line. Carefully check all connections for any sign of leakage.

5 Maintenance

Temperature / pressure gauge (optional) replacement

If the temperature / pressure gauge for the water tank is not functioning correctly and must be replaced, follow the procedure outlined below.

⚠ WARNING

The combination of electricity and water can pose a very dangerous situation. Turn off / disconnect all electric power before attempting any maintenance procedure.

1. Follow Steps 1 through 5 of the Shutdown Procedure on page 8 to take the unit off-line before attempting to replace the water temperature / pressure gauge.
2. Carefully unscrew the water temperature / pressure gauge from the port in the tank.
3. Install the new gauge into the port in the tank in place of the old one removed in Step 2. Follow recommendations contained in the manufacturer's documentation, local codes, or accepted contractor practices as to the use of joint compound or sealer at the connections.
4. Follow the Startup Procedures on page 8 to place the unit back on-line. Carefully check all connections for any sign of leakage.

Notes

Notes

Revision Notes: Revision A (ECO #C04161) initial release.

Revision B (ECO C12972) reflects the addition of the CSA Low Lead logo to the manual cover.

Revision C (ECO C13309) reflects the addition of FIG. 2-1 on page 5 and a note about saddle location.

Revision D (ECO C16201) reflects the update of the logo and removal of the gas warning on the manual cover, as well as the addition of the "Tank Pre-Start Flush" notice on page 7.

Revision E (ECO C16466) reflects the addition of four pages to the manual, a cold water supply section on page 6, the renaming of FIG.'s 2-2 and 2-3 as well as the addition of FIG. 2-4 on pages 5 and 6.

Revision F (PCP# 3000003860 / CN# 500009480) reflects updates made to FIG. 5-4 on page 12.