



Non-Condensing Boiler Protection for Low Temperature Systems

Motorized Low Temperature Valve

Designed for use with Power-Fin and Copper-Fin II Boilers

When designing a boiler system with return water temperatures below 130°F it is necessary to protect the boiler from heat exchanger condensation. All non-condensing boilers will develop operational problems if they are continually exposed to system return water temperatures below 130°F.

Typical systems that require this protection are water source heat pump systems, in-floor radiant heat systems, greenhouse heating, soil heating, process operations and manufacturing operations. Additionally, heating systems that utilize nighttime setback, night/weekend shutdown or outdoor reset control strategies should incorporate low water temperature protection.

To prevent low return water temperatures to the boiler and combat operational problems, the system should be piped in a primary secondary piping arrangement with a low temperature bypass. Manual bypass systems however are not the ideal solution due to varying flow rates and firing rate of the boiler.

A better alternative to use is Lochinvar's Motorized Low Temperature Valve, which is a motorized valve electronically controlled by the Smart System[®] control.

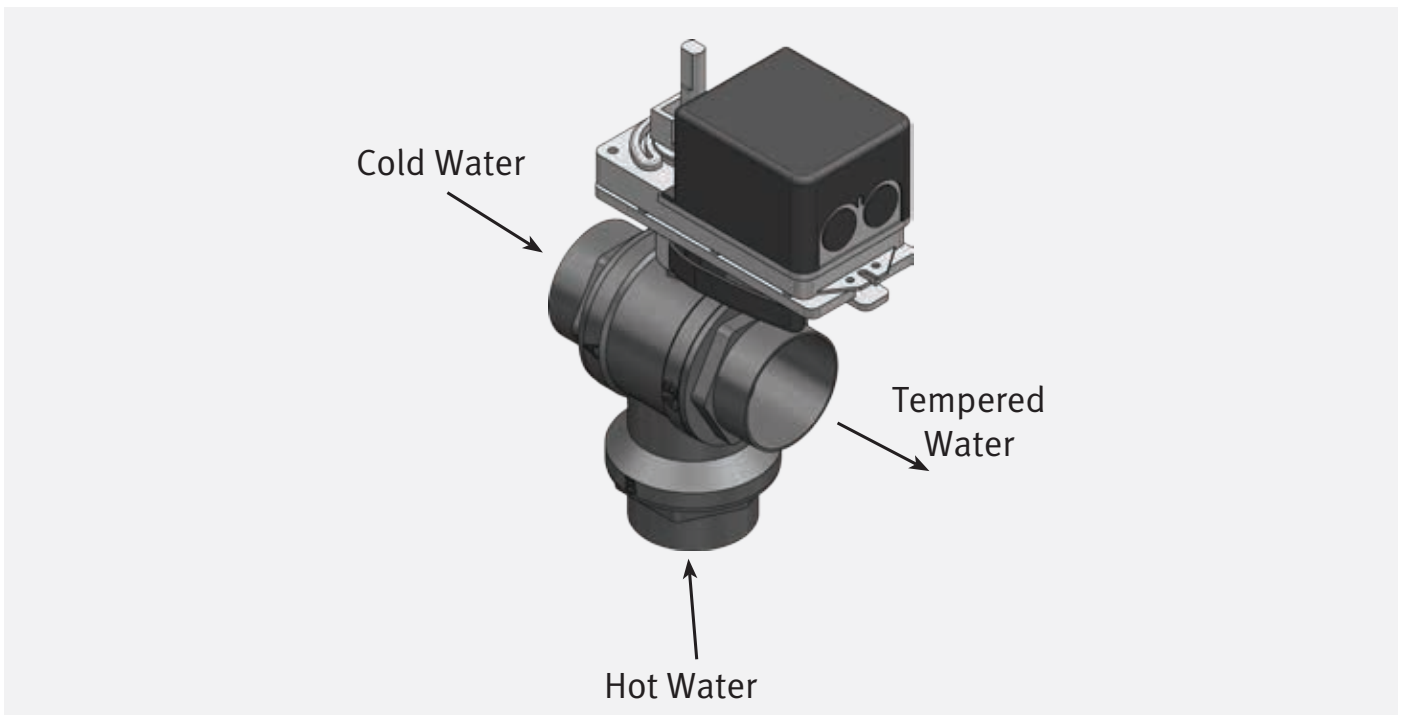

2-1/2" LTV Valve Dimensions - 100171920

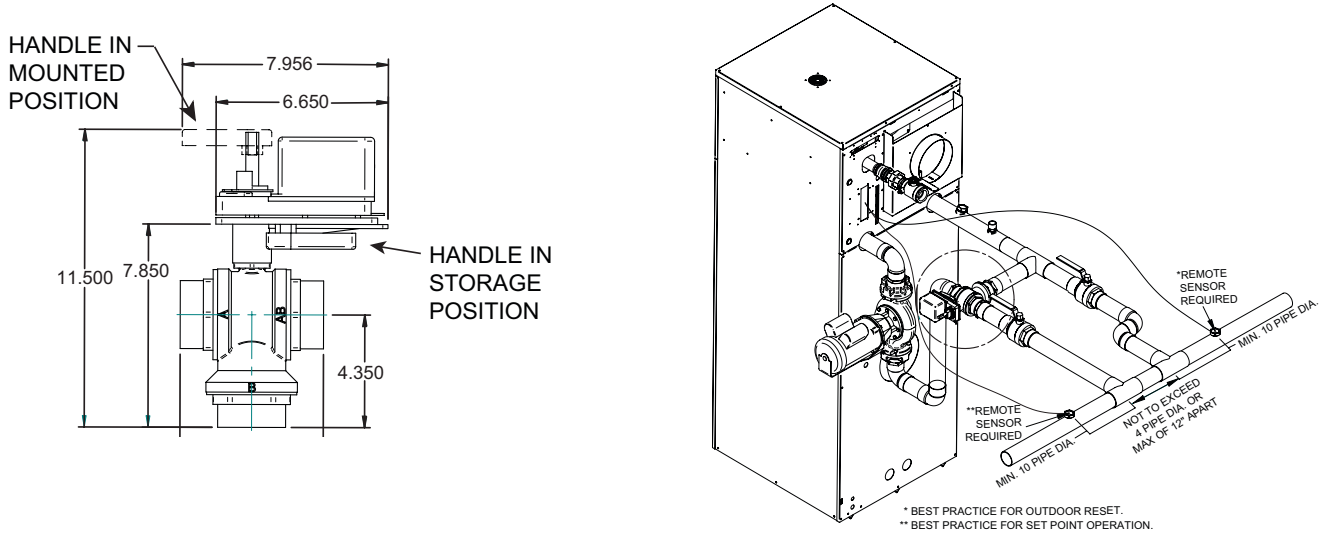

4" LTV Valve Dimensions - 100275913

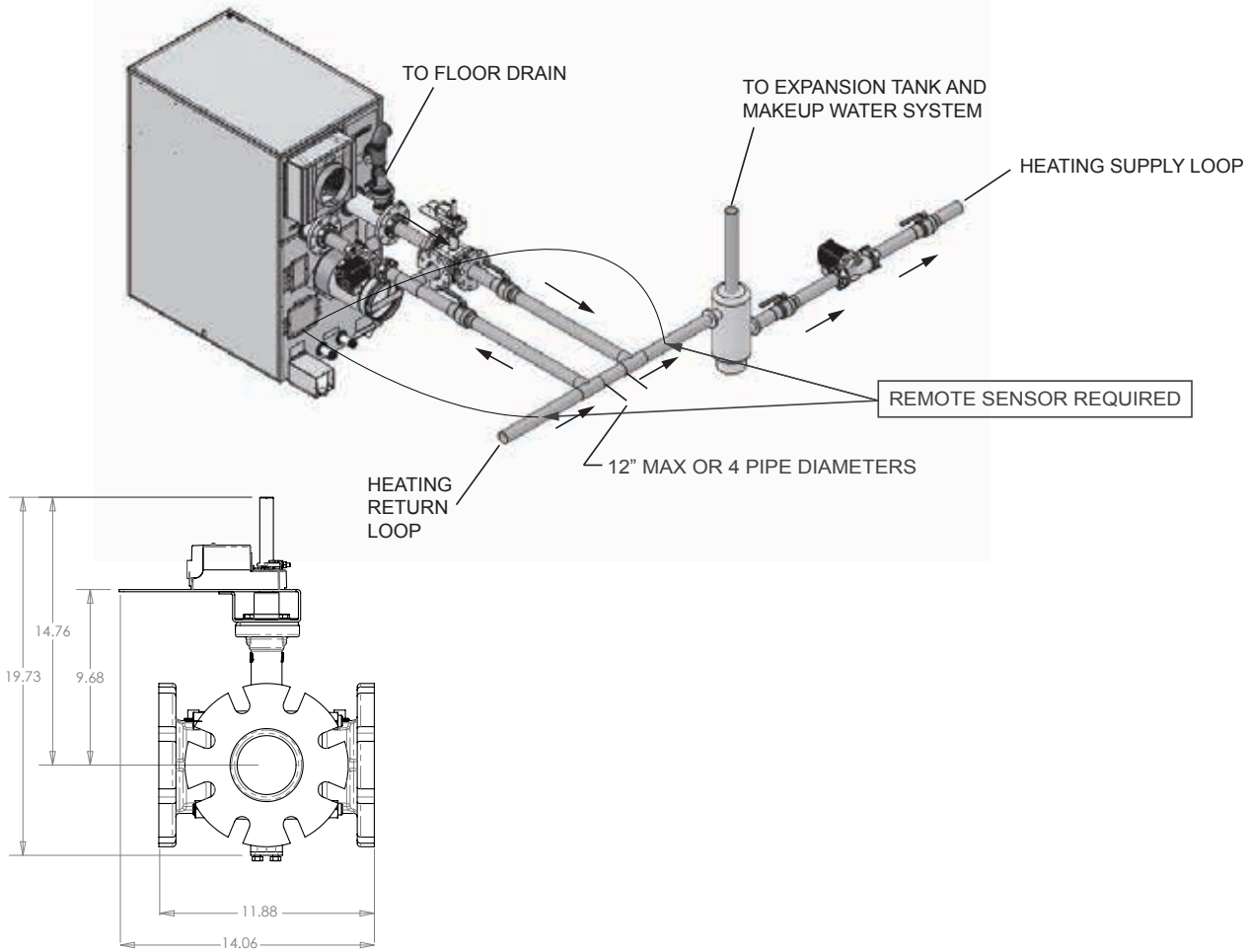

Lochinvar, LLC
 300 Maddox Simpson Parkway
 Lebanon, Tennessee 37090
 P: 615.889.8900 / F: 615.547.1000
[f](#) [t](#) [in](#) [v](#) [e](#) [c](#) [o](#) [m](#) [c](#) [o](#) [m](#)