

BOILER WIRING DIAGRAMS

LADDER WIRING DIAGRAM - HOT SURFACE IGNITION-F9

PB250-1000

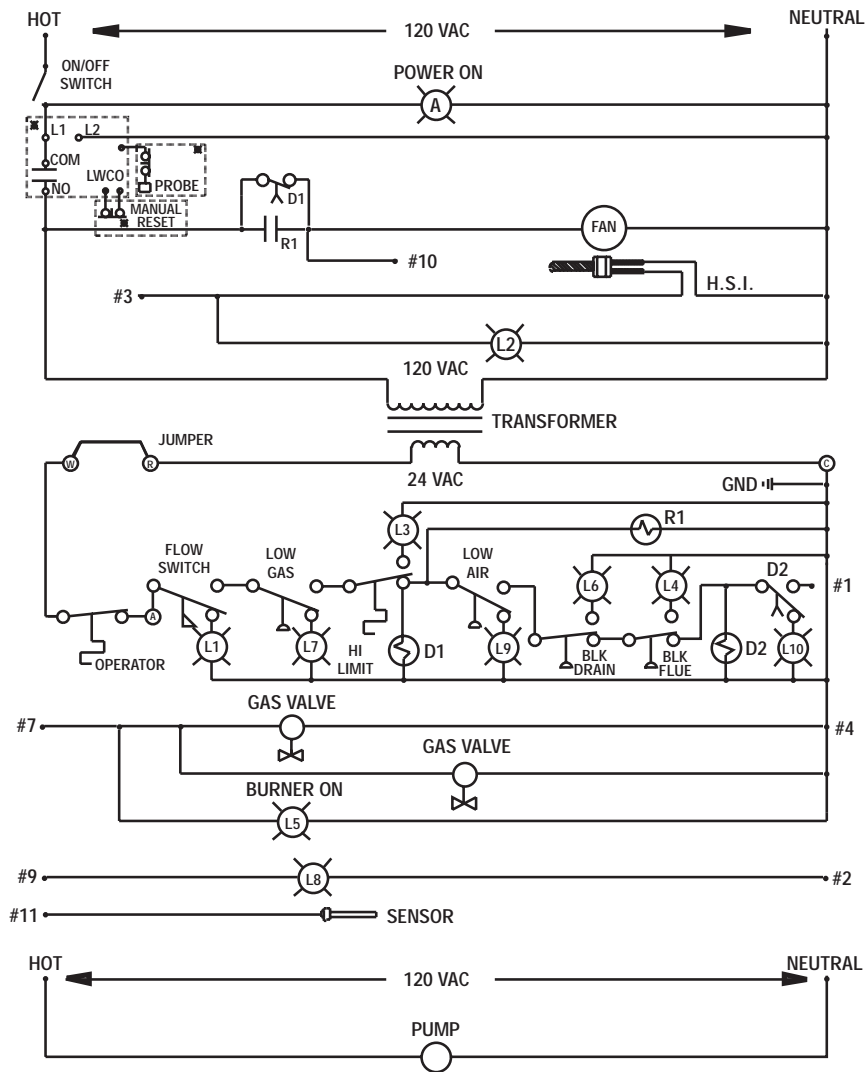

LAMP SCHEDULE

- L1 - RED-LOW WATER FLOW
- L2 - AMBER-TRIAL FOR IGNITION
- L3 - RED-HIGH WATER TEMPERATURE
- L4 - RED-BLOCKED FLUE
- L5 - GREEN-BURNER ON
- L6 - RED-BLOCKED DRAIN
- L7 - AMBER-LOW GAS PRESSURE
- L8 - RED-FLAME FAILURE
- L9 - RED-LOW AIR PRESSURE
- L10 - CLEAR-PRE-PURGE

NOTES:

1. #1 THROUGH #12 ARE CONNECTED ON IGNITION MODULE.
2. IF ANY OF THE ORIGINAL WIRE AS SUPPLIED WITH THE APPLIANCE MUST BE REPLACED, IT MUST BE REPLACED WITH TYPE 150° C WIRE OR ITS EQUIVALENT.
3. L3 WAS PRE-PURGE PRIOR TO SERIAL NO. J877683.
4. D1 IS POST-PURGE RELAY.
5. D2 IS PRE-PURGE RELAY.
6. LWCO IS LOW WATER CUT-OFF (OPTIONAL)
7. Ⓢ, Ⓢ, Ⓢ, AND Ⓢ IS TERMINAL STRIP FOR REMOTE OPERATOR

LIT0024

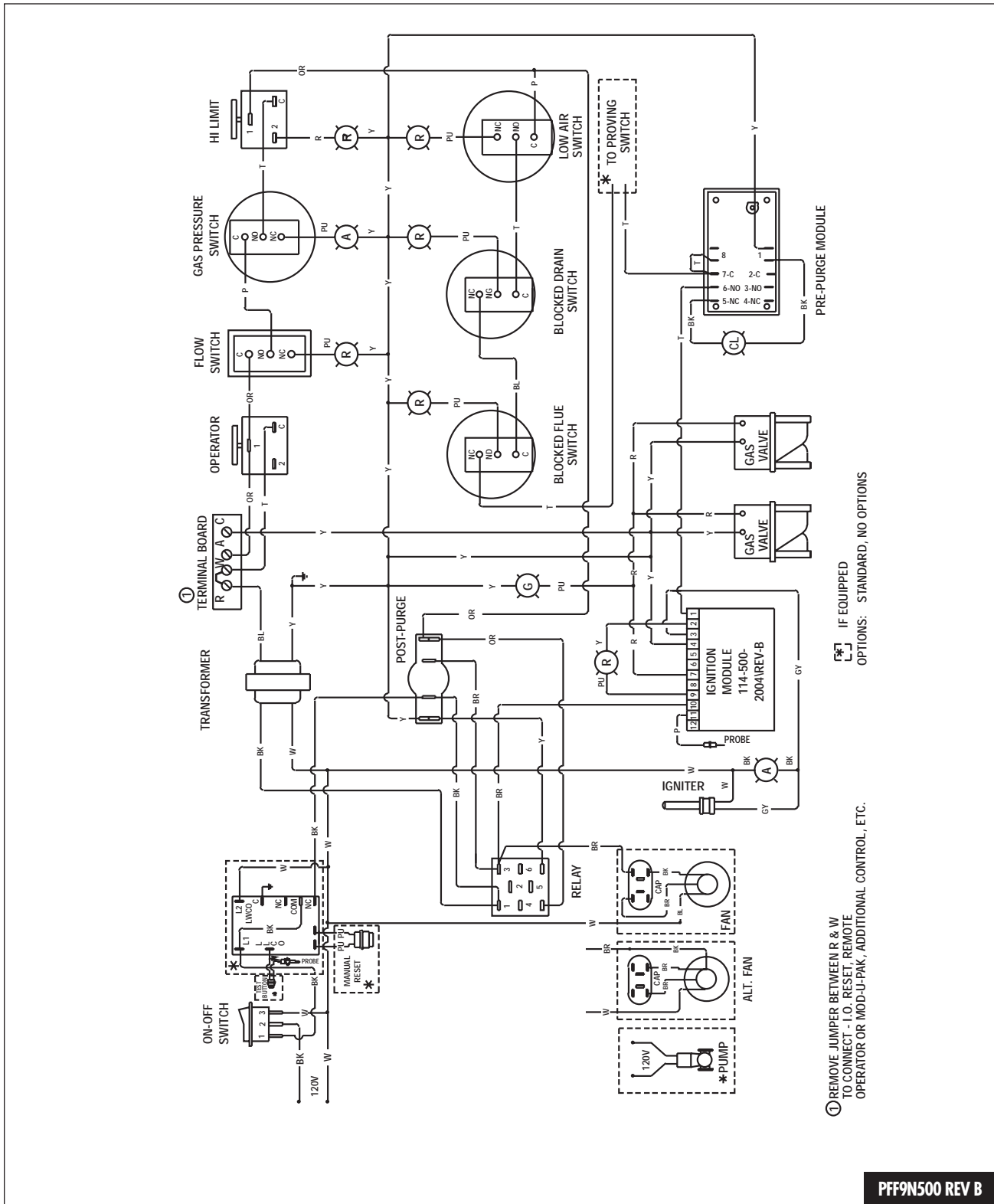

Lochinvar Corporation • 300 Maddox Simpson Pkwy • Lebanon, TN 37090 • 615-889-8900 / Fax: 615-547-1000
www.Lochinvar.com