



Ultra Low NOx Light Commercial Gas Water Heaters

Ultra Low NOx Models

Lochinvar's light commercial Ultra Low NOx model is available in 98 gallon capacity and meets South Coast Air Quality Management District Rule 1146.2 for less than 14 ng/j or 20 ppm NOx.

Standard Features

- **Automatic Gas Control with Safety Shutoff** – Automatic temperature selection at your fingertips. This accurate control provides an easy way to reset water temperature for best economy. An automatic over-heat safety device is standard.
- **Ultra Low NOx Burner** – Complies with South Coast Air Quality Management District Rule 1146.2 for less than 14 ng/j or 20 ppm NOx emissions.
- **Non-CFC Foam Insulation** - Superior material formulation provides uniform tank coverage with a 2" thick blanket of insulating foam. This non-CFC polyurethane closed cell foam minimizes standby losses and maximizes heat retention.
- **Glass-Lined Steel Tank** - The durable glass lining is fused to the tank at 1600°F to assure lasting protection against rust and corrosion while providing clean, clear hot water. 300 psi test pressure provides 150 psi working pressure.
- **Tank Saver Anode** - A large diameter, high capacity anode inhibits corrosion of the tank interior for long, trouble-free service.
- **Heat Trap** - The heat trap protects from heat loss through the water piping.
- **Temperature & Pressure Relief Valve** - Factory installed.
- **Brass Drain Valve** - Factory installed.
- **3- Year Limited Tank & 1-Year Parts Warranty** – See warranty for details.



All models meet or exceed the NAECA and ASHRAE Energy Efficiency Standards

Dimensions and Specifications

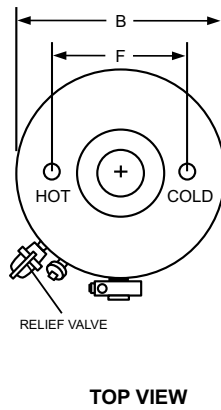
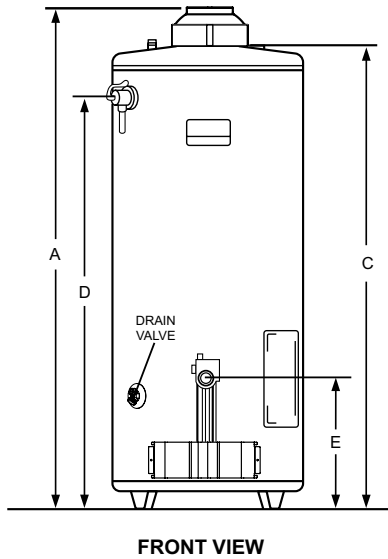

Model Number	Gal. Cap.	Input Btu/Hr	GPH @ 100°F Rise	A	B	C	D	E	F	Gas Conn.	Vent Size	Water Conn.	Ship. Wt.
Ultra Low NOx Models - 3 Year Warranty													
UTN100 75	98	75,100	74	70-1/2"	27-3/4"	66-1/2"	58-3/4"	15-1/4"	16"	1/2"	4"	1-1/4"	350

Notes: All Ultra Low NOx models certified at 14 ng/J or less.
Ultra Low NOx models available in Natural Gas ONLY.

Certified for Potable Water and Space Heating Applications

This water heater is suitable for water heating and space heating. Toxic chemicals, such as those used for boiler water treatment shall NEVER be introduced into this system. This water heater may NEVER be connected to any existing heating system or components previously used with non-potable water heating appliances.

For other models, see the "Ultra-Low NOx Commercial Gas Water Heaters" literature sheet.

FOR EASE IN ORDERING BY MODEL NUMBER

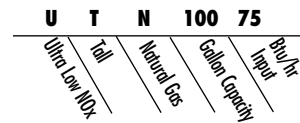

This is a tall Ultra Low NOx natural gas 98 gallon water heater with 75,100 Btu/hr input.



Lochinvar, LLC
300 Maddox Simpson Parkway
Lebanon, Tennessee 37090
P: 615-889-8900 / F: 615-547-1000
www.Lochinvar.com

