



Lochinvar[®]
High Efficiency Water Heaters, Boilers and Pool Heaters

**ULTRA LOW NO_x
LIGHT COMMERCIAL GAS
Submittal Sheet**

RUT-Sub-01a

ULTRA LOW NO_x LIGHT COMMERCIAL GAS WATER HEATERS

JOB NAME _____
LOCATION _____
ARCH./ENGR. _____
WHOLESALE _____
MECH. CONTRACTOR _____
MODEL NO. _____
TYPE GAS _____
Btu/hr INPUT _____
RECOVERY RATE IN GPH _____ @ _____ °F RISE
NOTES

Standard Features

- Automatic Gas Control with Safety Shutoff
- Ultra Low NO_x Burner
- Non-CFC Foam Insulation
- Glass-Lined Steel Tank
- Tank Saver Anode
- Heat Trap
- Temperature & Pressure Relief Valve
- Brass Drain Valve
- 3- Year Limited Tank & 1-Year Parts Warranty.
See warranty for details

Dimensions and Specifications

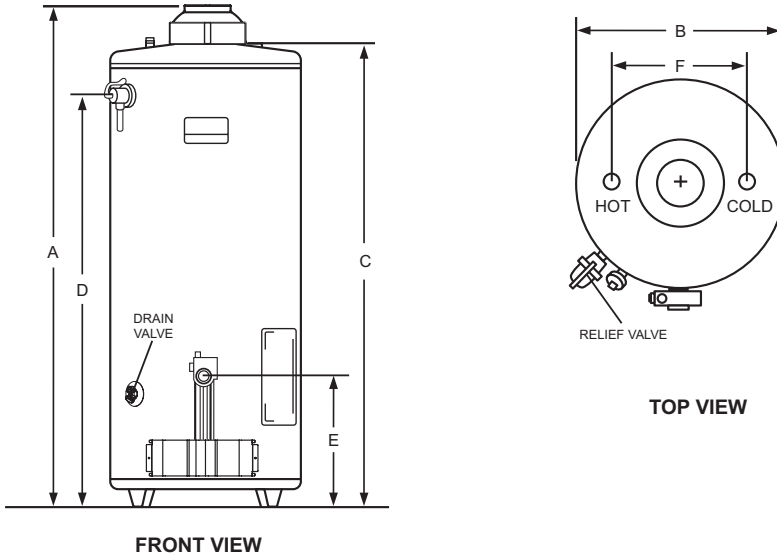

Model Number	Gal. Cap.	Input Btu/Hr	GPH @ 100°F Rise	A	B	C	D	E	F	Gas Conn.	Vent Size	Water Conn.	Ship. Wt.
Ultra Low NOx Models - 3 Year Warranty													
UTN10075	98	75,100	74	70-1/2"	27-3/4"	66-1/2"	58-3/4"	15-1/4"	16"	1/2"	4"	1-1/4"	350

Notes: All Ultra Low NOx models certified at 14 ng/J or less.
 Ultra Low NOx models available in Natural Gas ONLY.



Lochinvar, LLC • 300 Maddox Simpson Pkwy • Lebanon, TN 37090 • 615-889-8900 / Fax: 615-547-1000
www.Lochinvar.com