

RESIDENTIAL GAS WATER HEATERS

Lochinvar's 8-Year residential gas models are available in 40, 50 and 55 gallon capacities in short and tall configurations with a standard 8-year warranty.

STANDARD FEATURES

- **Code Compliance** - Complies with the Federal Energy Conservation Standards effective April 16, 2015, in accordance with the Energy Policy and Conservation Act, (EPCA), as amended.
- **Flammable Vapor Ignition Resistant** - Combustion air is directed through a stainless steel flame arrestor plate specifically designed to prevent flame rollout and flammable vapor ignition. The design includes a safety thermal switch and protection from lint, dust and oil buildup.
- **Electronic Gas Control** - The gas valve features an internal microprocessor for precise temperature control, fast response and an LED status indicator for simplified service diagnostics. The valve is powered by a thermopile pilot requiring no external power source.
- **Low NOx Burner** - The patented radial burner design reduces NOx emissions by more than 33% delivering less than 40 ng/j of NOx.
- **Glass-Lined Steel Tank** - The durable glass lining is fused to the steel tank at 1600°F to assure lasting protection against rust and corrosion while providing clear, clean hot water. 300 PSI test pressure; 150 PSI working pressure.
- **Non-CFC Foam Insulation** - A uniform coverage of thick closed-cell foam insulation minimizes standby heat loss, maximizes heat retention and delivers a high Energy Factor.
- **Tank Saver Anode** - A large diameter, high capacity anode inhibits corrosion of the tank interior for long, trouble-free service.
- **Heat Trap** - Heat traps are built into the inlet and outlet connections to eliminate heat migration and heat loss in the water piping.
- **Temperature & Pressure Relief Valve** - Factory installed for optimum safety.
- **Brass Drain Valve** - An enhanced ball valve design for effective drainage and positive shut-off.
- **8-Year Limited Tank & Parts Warranty*** – See warranty sheet for details.
- **4-Year Extended Warranty Kit** – Available for residential applications only.

*1-year limited tank & parts warranty when installed in a commercial application.

ENERGY SAVER 8-YEAR GAS MODELS



Meets ASHRAE Energy Efficiency Standards



HIGH EFFICIENCY BOILERS & WATER HEATERS

DIMENSIONS & SPECIFICATIONS

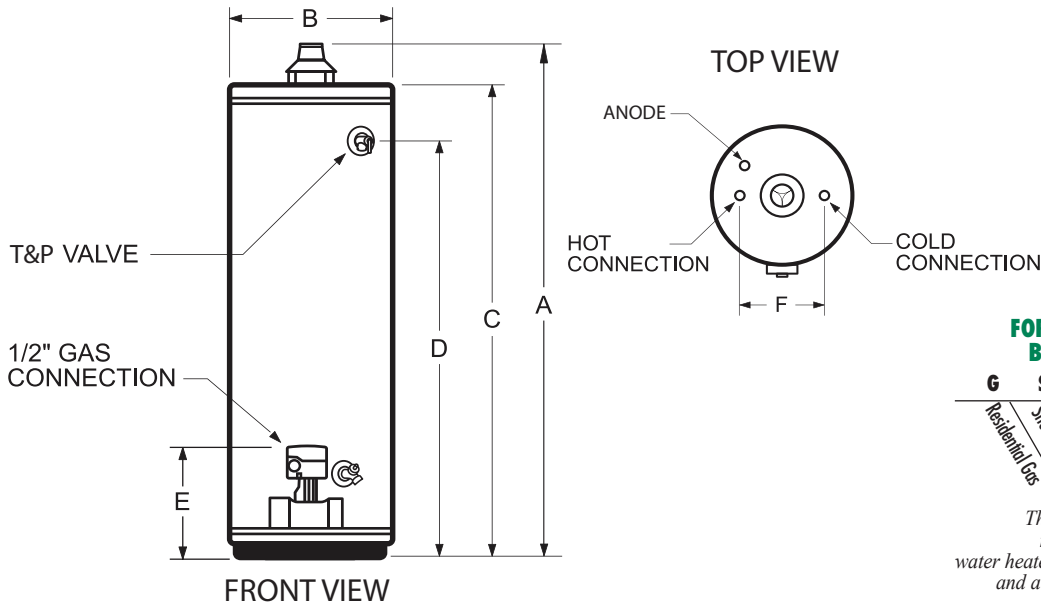

**FOR EASE IN ORDERING
BY MODEL NUMBER**

G S N 030 32 -8

Residential Gas / Short / Natural Gas / Gallon Capacity / Input Rate / 8-Yr Warranty

This is a short residential natural gas 30 gallon water heater with 32,000 Btu/Hr input rate and a standard 8-year warranty.

Model Number	Nominal Gal. Cap.	Rated Storage Cap.	Rated Btu/Hr Input	LP Gas Btu/Hr	UEF	1st Hr. Rating	GPH @ 90°F Rise	A	B	C	D	E	F	Gas Conn.	Water Conn.	Vent Size	Ship. Wt.
8 Year - Short Models																	
GSN040 40-8	40	38	40,000	36,000	0.58	67	41	51-1/2"	22"	48"	41-1/4"	12"	8"	1/2"	3/4"	3" or 4"	135
GSN050 40-8	50	50	40,000	40,000	0.62	81	43	53-1/4"	24"	49-3/4"	41-1/2"	12"	8"	1/2"	3/4"	3" or 4"	177
8 Year - Tall Models																	
GTN040 40-8*	40	38	40,000	36,000	0.66	80	42	61-3/4"	20"	58-1/4"	52"	12-1/4"	8"	1/2"	3/4"	3" or 4"	138
GTN050 40-8*	50	48	40,000	37,000	0.62	81	41	60-3/4"	21"	57-1/4"	50-1/2"	12-1/4"	8"	1/2"	3/4"	3" or 4"	148
GTN050 50-8*	50	48	50,000	45,000	0.61	89	54	60-3/4"	22"	57-1/4"	50-1/2"	12-1/4"	8"	1/2"	3/4"	4"	165
GTN055 60-8*	55	55	60,000	54,000	0.62	83	65	59-3/4"	24"	55-1/4"	48"	13-1/2"	8"	1/2"	3/4"	4"	185

Notes: In the model number, "N" indicates Natural gas; replace "N" with "L" to indicate L.P. gas models
 * Optional Side Tappings are available on these models. Add "ST" to the end of the model number (Ex: GTN04040-8ST).

Certified for Potable Water and Space Heating Applications
 This water heater is suitable for water heating and space heating. Toxic chemicals, such as those used for boiler water treatment shall NEVER be introduced into this system. This water heater may NEVER be connected to any existing heating system or components previously used with non-potable water heating appliances.



Lochinvar, LLC
 300 Maddox Simpson Parkway
 Lebanon, Tennessee 37090
 P: 615.889.8900 / F: 615.547.1000
 Lochinvar.com

For technical information call 800-722-2101. Lochinvar, LLC reserves the right to make product changes or improvements without prior notice.