

RESIDENTIAL GAS WATER HEATERS

Lochinvar's Energy Saver residential gas models are available in 30, 40, and 50 gallon capacities in short and tall configurations.

ENERGY SAVER GAS MODELS

STANDARD FEATURES

CODE COMPLIANCE –Complies with the Federal Energy Conservation Standards effective April 16, 2015, in accordance with the Energy Policy and Conservation Act, (EPCA), as amended.

FLAMMABLE VAPOR IGNITION RESISTANT - The combustion system meets the American National Standards Institute standards (ANSI Z21.10.1/CSA 4.1) for prevention of accidental or unintended ignition of flammable vapors, such as gasoline vapor. The water heater features a sealed combustion chamber with intake air filtration and a flame arrestor.

ELECTRONIC GAS CONTROL - The gas valve features an internal microprocessor for precise temperature control, fast response and an LED status indicator for simplified service diagnostics. The valve is powered by a thermopile pilot requiring no external power source.

LOW NOX BURNER - The patented radial burner design reduces NOx emissions by more than 33% delivering less than 40 ng/j of NOx.

GLASS-LINED STEEL TANK - The durable glass lining is fused to the steel tank at 1600°F to assure lasting protection against rust and corrosion while providing clear, clean hot water. 300 PSI test pressure; 150 PSI working pressure.

NON-CFC FOAM INSULATION - A uniform coverage of thick closed-cell foam insulation minimizes standby heat loss, maximizes heat retention and delivers a high Uniform Energy Factor.

TANK SAVER ANODE - A large diameter, high capacity anode inhibits corrosion of the tank interior for long, trouble-free service.

HEAT TRAP - Heat traps are built into the inlet and outlet connections to eliminate heat migration and heat loss in the water piping.

TEMPERATURE & PRESSURE RELIEF VALVE - Factory installed for optimum safety.
Brass Drain Valve - An enhanced ball valve design for effective drainage and positive shut-off.

6-YEAR LIMITED TANK & PARTS WARRANTY* – See warranty sheet for details.
10-Year Extended Warranty – Available for residential applications only.
*1-year limited tank & parts warranty when installed in a commercial application.

OPTIONAL FEATURES

VOLTAGES AVAILABLE—120, 208, 240 volts.(Wired for single phase only)
For 277, 380, 415 & 480 volts, and all 3 phase, see Light Duty Commercial Water Heaters



Lochinvar[®]
HIGH EFFICIENCY BOILERS & WATER HEATERS

DIMENSIONS AND SPECIFICATIONS

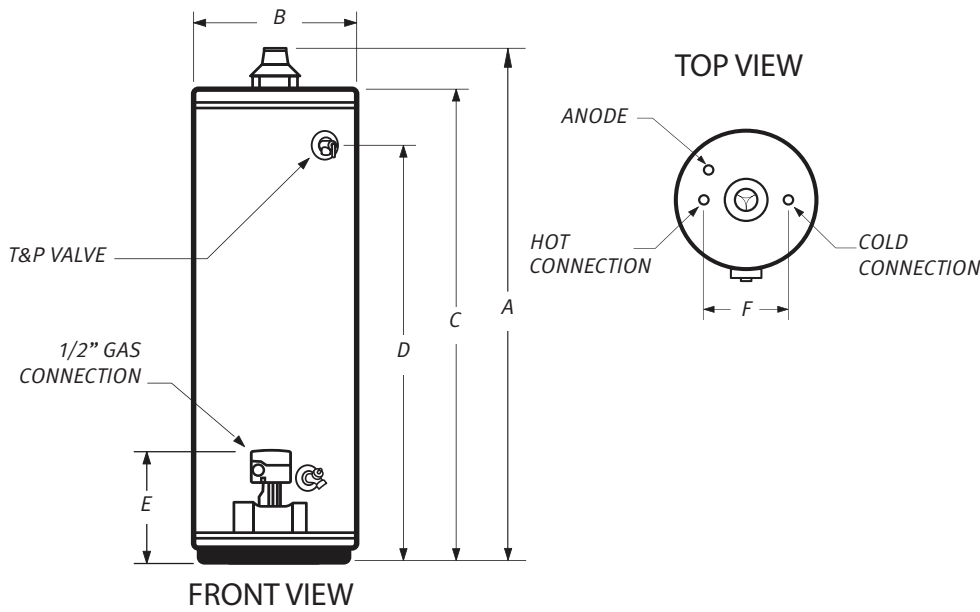

FOR EASE IN ORDERING BY MODEL NUMBER

G	S	N	030	32
Residential Gas	Short	Natural Gas	Gallon Capacity	Input Rate

This is a short residential natural gas 30 gallon water heater with 32,000 Btu/Hr input rate.

Model Number	Nominal Gal. Cap.	Rated Storage Cap.	Nat. Gas Btu/Hr Input	LP Gas Btu/Hr Input	UEF	1st Hr. Rating	GPH @ 90°F Rise	A	B	C	D	E	F	Gas Conn.	Water Conn.	Vent Size	Ship. Wt.
Energy Saver with Insulation Blanket - Short Models																	
GSN030 32BR	30	29	32,000	29,000	0.60	65	32	50-1/4"	18"	46-3/4"	40"	14"	8"	1/2"	3/4"	3" or 4"	114
GSN040 40B	40	38	40,000	36,000	0.57	68	41	51-1/2"	20"	48"	41-1/4"	12"	8"	1/2"	3/4"	3" or 4"	134
Energy Saver - Short Models																	
GSN030 32R	30	29	32,000	29,000	0.60	55	32	50-1/4"	20"	46-3/4"	40"	14"	8"	1/2"	3/4"	3" or 4"	108
GSN040 40	40	38	40,000	36,000	0.58	67	41	51-1/2"	22"	48"	41-1/4"	12"	8"	1/2"	3/4"	3" or 4"	135
GSN050 40	50	50	40,000	40,000	0.62	81	43	53-1/4"	24"	49-3/4"	41-1/2"	13-1/4"	8"	1/2"	3/4"	3" or 4"	177
Energy Saver with Insulation Blanket - Tall Models																	
GTN030 32BR	30	29	32,000	30,000	0.60	62	32	60-1/2"	16"	57"	51"	14"	8"	1/2"	3/4"	3" or 4"	123
GTN040 40B	40	38	40,000	36,000	0.65	78	42	61-3/4"	18"	58-1/4"	52"	12-1/4"	8"	1/2"	3/4"	3" or 4"	130
GTN050 60B*	50	49	60,000	54,000	0.61	99	65	65-1/2"	22"	61"	54-1/4"	13-1/2"	8"	1/2"	3/4"	4"	182
Energy Saver - Tall Models																	
GTN030 32R	30	29	32,000	29,000	0.60	62	31	60-1/2"	18"	57"	51"	14"	8"	1/2"	3/4"	3" or 4"	132
GTN040 35	40	38	35,500	N/A	0.59	65	38	61-3/4"	20"	58-1/4"	52"	12-1/4"	8"	1/2"	3/4"	3" or 4"	138
GTN040 40*	40	38	40,000	36,000	0.64	80	42	61-3/4"	20"	58-1/4"	52"	12-1/4"	8"	1/2"	3/4"	3" or 4"	138
GTN050 40*	50	48	40,000	37,000	0.62	81	41	60-3/4"	21"	57-1/4"	50-1/2"	12-1/4"	8"	1/2"	3/4"	3" or 4"	148
GTN050 50*	50	48	50,000	45,000	0.61	89	54	60-3/4"	22"	57-1/4"	50-1/2"	12-1/4"	8"	1/2"	3/4"	4"	165
GTN055 60*	55	55	60,000	54,000	0.62	83	65	59-3/4"	24"	55-1/4"	48"	13-1/2"	8"	1/2"	3/4"	4"	185

Notes: In the model number, "N" indicates Natural gas; replace "N" with "L" to indicate L.P. gas models
 * Optional Side Tappings are available on these models. Add "ST" to the end of the model number (Ex: GTN04040ST).
 **GTN05060B and GTN05560 receive White Rogers gas valve, standard.
 ***"R" added to model number for model revision.

For technical information call 800-722-2101. Lochinvar, LLC reserves the right to make product changes or improvements without prior notice.



Lochinvar, LLC
 300 Maddox Simpson Parkway
 Lebanon, Tennessee 37090
 P: 615.889.8900 / F: 615.547.1000
Lochinvar.com

